

LIGHTGATE

Dot-Matrix Hologram Mastering System - 1996

*A Technical and Historical Overview*

*Rob Munday*



## Lightgate - Dot-Matrix Hologram Mastering System - 1996

*by Rob Munday*



*The Lightgate B system, 2004.*

### **What is a dot-matrix hologram**

Dot-matrix holograms are a distinct type of hologram whose origination, appearance, and viewing characteristics differ fundamentally from those of conventional holography. They consist of thousands, and often millions of microscopic "dots," each containing a precisely formed diffraction grating. These dots are usually recorded individually, under computer control, by converging two or more focused laser beams to a common point to create a tiny interference pattern. Because dot-matrix holograms are generated from computer-created imagery and typically recorded onto photoresist to produce surface-relief structures, they are easy to view under almost any lighting conditions. Crucially, the orientation and spatial frequency of the grating within each dot can be independently specified, enabling the creation of complex, fully synthetic imagery and making dot-matrix holograms a mainstay of optical security and anti-counterfeiting applications. See: *The principles of dot-matrix holography* below.

## A eureka moment

In August of 1996, one summers evening while relaxing in the bath at home, I experienced a eureka moment that would shape the technical side of my holographic career and drive the business of my company, Spatial Imaging Ltd., for the next thirty years.

I had been tasked by Walter Clarke, a Canadian-Irish investor and owner of the American holography company Global Images Inc., earlier that year, to design and build a dot-matrix hologram-mastering system. Walter had previously purchased two of my DI-HO digital holographic stereogram mastering systems for his security hologram companies in China and India, but he had recognised the potential advantages of dot-matrix technology for security-hologram origination.

By August 1996, only four dot-matrix hologram mastering systems were known, and just one was commercially available.

1. **1984** - Iwata Fujiro of Toppan Printing Co. Ltd. patented a proprietary dot-matrix hologram system that initially provided variable grating spatial frequency only. A rotating plateholder was later introduced to add variable grating orientation.
2. **1986** - Frank S. Davis invented the Light Machine. With subsequent technical contributions from Kenneth (Ken) Harris of Dimensional Arts Inc., it became the first commercially available system in 1991. It was also the first dot-matrix mastering system capable of varying both grating orientation and spatial frequency.
3. **1990** - Craig Newswanger of Applied Holographics plc. built a proprietary system that employed a rotating diffraction grating to generate and rotate the two interfering beams.
4. **1996** - Chih-Kung Lee of National Taiwan University designed a system that was later, in 1998, branded and sold by Ahead Optoelectronics, Inc. as the *Sparkle System*.

Below are diagrams of the optical configurations for the Light Machine and the later commercially available Sparkle system. Both relied on large assemblies of glass beamsplitters (BS) and mirrors to split and then recombine pairs of beams. In the Light Machine, only three object beams (OB) were arranged at different angles to the reference beam (RB), allowing the selection of just three grating spatial frequencies (colours). For both systems, the entire optical assembly had to move, rotate, stop, and settle before each diffractive pixel could be recorded, resulting in machines that were cumbersome, alignment-sensitive, and slow. The Davis Light Machine could not produce security holograms or holographic stereograms, and all existing technologies were limited in capability and features.

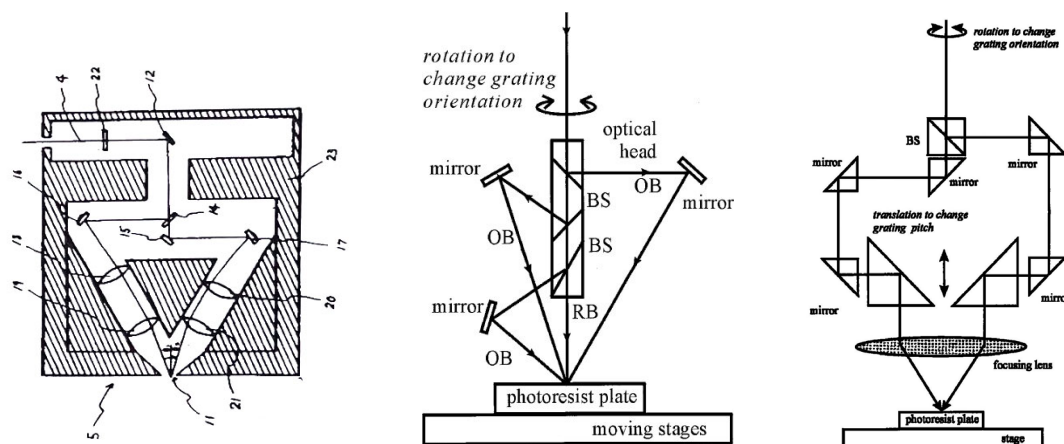

Left: Diagram of the dot-matrix system patented in 1984 by Iwata Fujiro of Toppan Printing Co. Ltd. which used two independently driven rotating mirrors to scan two beams through lenses, providing a variable spatial frequency only.  
 Centre: Diagram of the optically complex Davis Light Machine, sold by Dimensional Arts Inc. from 1991.  
 Right: Diagram of the even more optically complex C. K. Lee / Sparkle system, sold by Ahead Optoelectronics Inc. from 1998.

Keen to avoid replicating any of the existing technologies, I spent several weeks trying to devise a unique and original approach. Then, as I relaxed in the bath, an idea struck me - so simple and so much more elegant than any other system that I was convinced there must be a reason it couldn't work. By the next morning, having failed to think of one, I eagerly travelled to my studio at 8 Wheatash Road, Addlestone, Surrey, to test the idea.

The concept couldn't have been simpler: make two holes in a thin piece of cardboard and place it in a diverging laser beam. The mask would block all but the light passing through the two apertures, creating two spatially separated coherent beams of light. A single lens placed in front would then bring those beams to a common, overlapping focal point. At that intersection, the beams would interfere, and the resulting interference pattern would be recorded as a diffractive pixel.

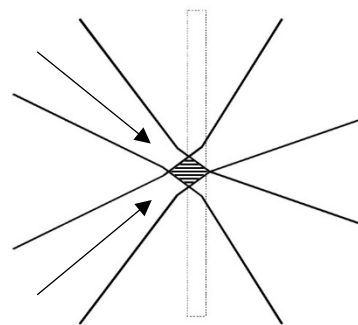
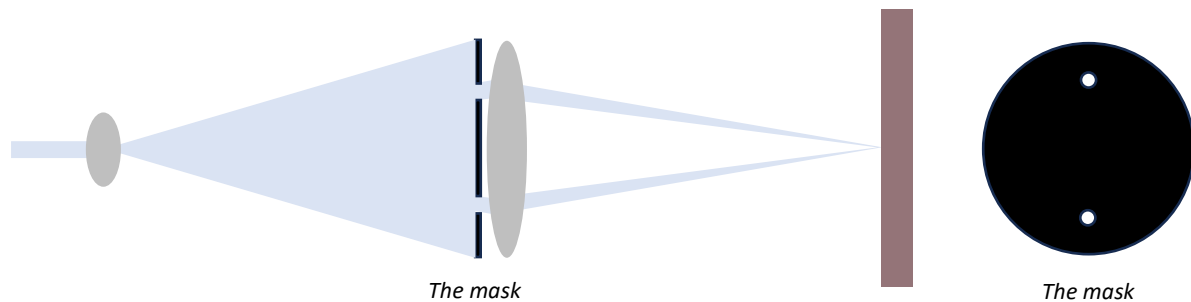

*The Lightgate optical principle.*

Arriving at the studio, I realised that I could use my DI-HO system's optical recombiner to translate a photoresist plate in X and Y directions to make a test, and so I quickly wrote a simple software routine on my Amiga computer to step it in very small, pixel sized increments between exposures. I then set up the optical components seen in the diagram above, an expanding lens to diverge the beam, a thin piece of cardboard with two holes, and a large lens to reconverge and focus the resulting pair of beams onto the photoresist plate. With excitement I exposed a small 50 x 50-pixel area.

At that time, the highest-resolution, and indeed the only commercially available system in the world was the Dimensional Arts Light Machine, with a resolution of only 100-200 diffractive pixels per inch and a speed of only 1-2 exposures per second. After developing my very first test, and seeing bright rainbow colours diffract from its surface, I placed it under a microscope and, to my amazement, discovered a perfect 1 x 1mm square dot-matrix hologram with a resolution of 1,270 dpi - some six to twelve times higher resolution than the Light Machine. What's more, and with further testing, a speed of 20 pixels per second was achieved, 10-20 times faster than the competition. In short, I had built the highest-resolution and fastest dot-matrix system in the world.

The rest is history. The idea worked, no one else had conceived of this method, and that single eureka moment resulted in the second commercially available dot-matrix hologram mastering system, the bestselling dot-matrix hologram mastering system ever built, and the first dot-matrix hologram mastering system capable of making complex and sophisticated security holograms, spawning a whole new security hologram industry worldwide.

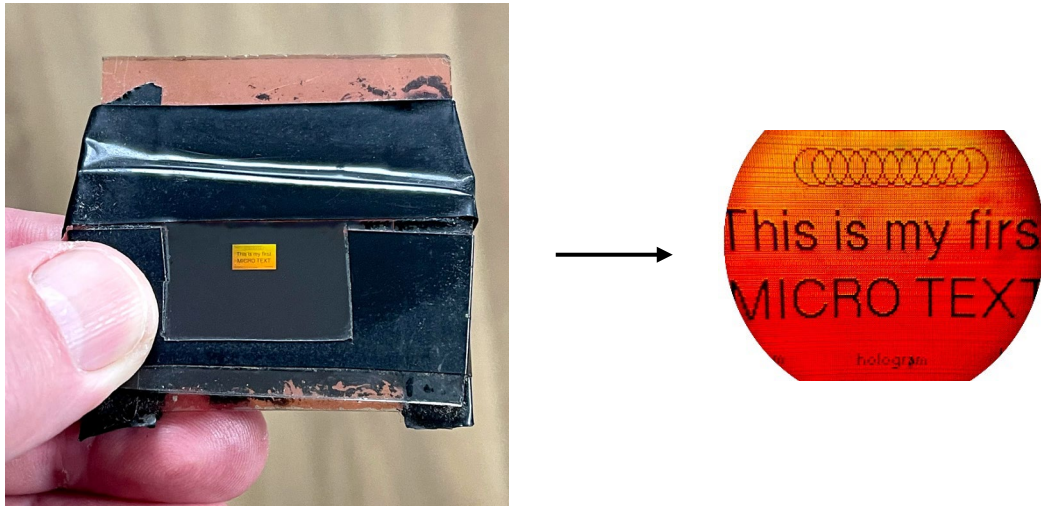

*The second hologram test made in August 1996 – 1:1 scale.  
Thought to be the first dot-matrix hologram to contain microtext and micropatterns.  
The microtext recorded was just 80  $\mu\text{m}$  (0.08 mm) high.*

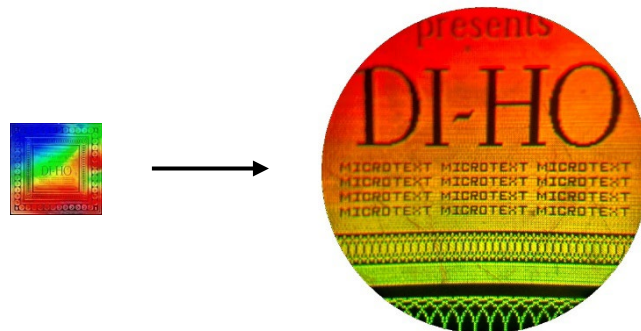

*The third hologram test made in August 1996 – 1:1 scale.  
Containing 100  $\mu\text{m}$  (0.1 mm) high microtext.*

My initial intention was to name the system under the established DI-HO brand, but my investor, Walter Clarke, proposed *Lightgate*. I added 1270 to denote its resolution, and thus the Lightgate 1270 was born.

It's often said that the simplest ideas are the best, and this one proved it, generating multi-million-pound revenues for Spatial Imaging over the years that followed.

Significant advantages of my optical configuration included:

- **The interfering beams are simply two, or four parts of a single converging beam**, which means:
  - a) their path lengths are inherently identical, allowing the use of lasers with very short coherence lengths,
  - b) their focal spots remain always perfectly aligned with one another,
  - c) their focal spots are near circular in cross-section,
  - d) there is no movement of the convergence point along the optical axis as the angle between the two beams is varied.
- **The system contains no moving optical components**, eliminating sources of mechanical drift or instability in the interfering beams.
- **The only moving element is a simple, lightweight mask** (later two masks) that can be rotated at high speed, dramatically reducing the exposure time required to record a dot-matrix hologram.
- **The compact optical system fits within an open-frame XY table and beneath the photoresist plate, which lays face down**, thus:
  - a) Providing a highly stable platform,
  - b) Preventing dust from settling on the photosensitive surface,
  - c) Shielding the photosensitive surface from ambient light,
  - d) Enabling straightforward visual focus alignment using a microscope from above and,
  - e) Ensuring that focus remains consistent regardless of variations in photoresist plate thickness.

Having now proven the concept, the next step was to build a simple mechanical system to rotate the mask, and therefore the two interfering beams, to any orientation. This was simple enough. I made a more rigid mask, this time from a thin sheet of aluminium, drilled two 1mm diameter holes in it, and mounted it in such a way that it could be rotated using a stepper motor under computer control. It was at this point that my Lightgate Control software program was born. The program needed to rotate the mask, and hence the two interfering beams, in accordance with the grey level of the pixel in the computer bitmap image being recorded - see later for a full explanation of the dot matrix principle.

This simple technique, whereby the grating orientation is rotated for each diffractive pixel, creates a moving colour effect as the hologram is tilted, and so I termed this kind of dot-matrix hologram a 'kinetic' hologram.

Having written the software, I then created the first and second embossed kinetic holograms to be made using a high-resolution Lightgate dot-matrix system during September 1996, see below



*The first simple, high-resolution 'kinetic' dot-matrix hologram made using a Lightgate in September 1996.*

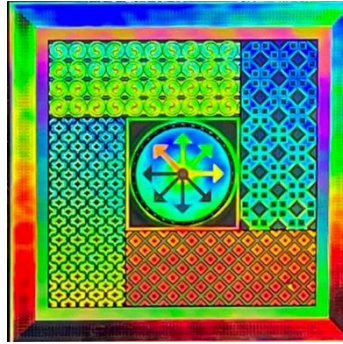

*The second high-resolution 'kinetic' dot-matrix hologram made using a Lightgate in September 1996.*



*A simple single spatial frequency 'kinetic' Lightgate dot-matrix hologram to authenticate Seagate hard drives.*

The next significant development followed quickly in January 1997. Whilst it was now possible to create high-resolution, single frequency (single colour) kinetic holograms, such as the commissioned hologram to authenticate Seagate hard drives shown above, the final challenge was to invent a method to additionally move the two beams closer together or further apart, i.e. change the angle between them. By doing so, it would then be possible to also change the spatial frequency, and thus the relative colour, of each diffractive pixel on the fly.

Not only that, but by being able to continuously change both the grating orientation and the grating spatial frequency at the same time, it would be possible to diffract the light from any given pixel in the hologram through any angle and thus to any point in space. This would ultimately lead me to develop several highly sophisticated optical features including the first dot-matrix covert laser projected hidden images and the first dot-matrix full colour, wide-angle holographic stereograms, for which I won a coveted International Hologram Manufacturers 'Award of Excellence' in the year 2000 – see *LPI* and *3Digital* below.

Initially, I explored the idea of using a single electronically addressable mask in the form of a TFT LCD, but the poor contrast of LCDs at that time rendered this approach unviable. To address the contrast problem, I next tried combining a physical mask with an LCD: the physical mask would contain multiple holes or slotted apertures, and these would be selectively masked and modulated by the LCD. This idea formed the basis of my first patent application, drafted in the autumn of 1996 and filed on 4<sup>th</sup> January 1997 - see *Patent Applications* below. A further difficulty then emerged: scatter and diffraction from the LCD itself, which generated multiple unwanted focal points on the output plane. Although this limitation was largely mitigated by placing a conical mask close to the recording medium, the LCD approach was soon superseded.

In late January 1997, a second eureka moment presented itself. It occurred to me that the simplest and most reliable way to generate two beams with any chosen orientation and angular separation was to use a pair of physical masks: one containing two slotted apertures and the other containing two spiral apertures. The slotted mask would define the orientation of the resultant diffraction grating, while the spiral mask would determine its spatial frequency.

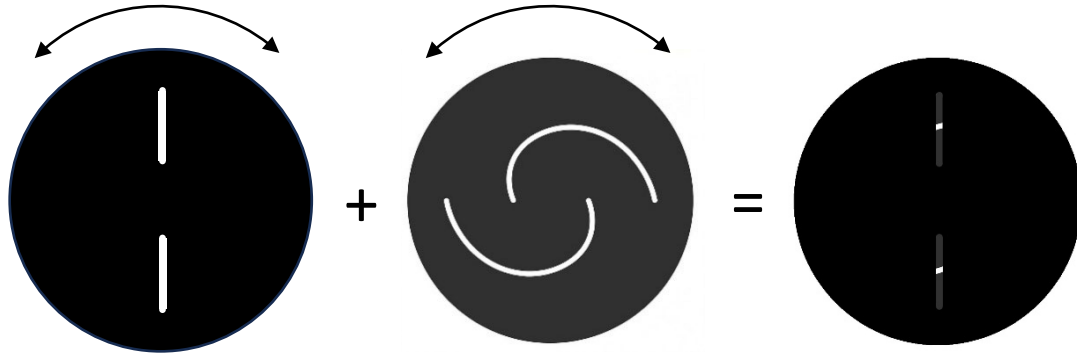

*Twin masks for the selection of both grating orientation and grating spatial frequency on the fly.*

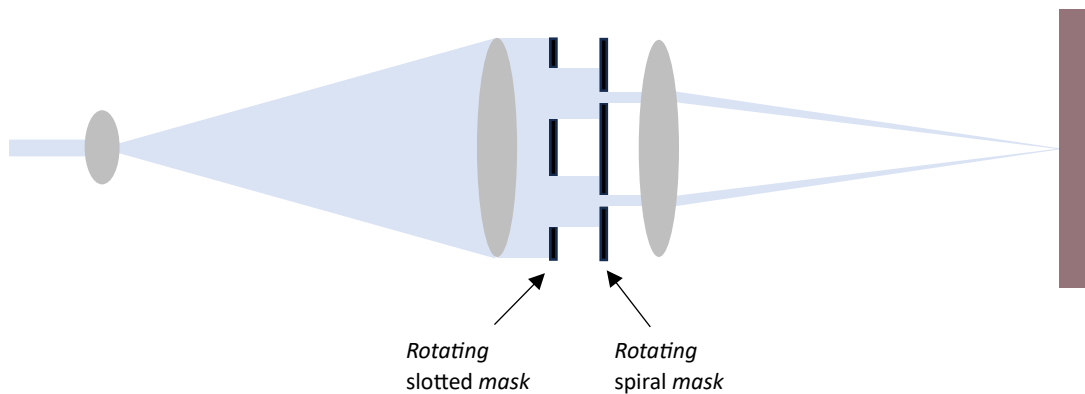

*The final optical configuration for the Lightgate 1270.*



*Left: A brand authentication hologram for Disney made using the Lightgate 1270 system, comprising of kinetic, guilloche, laser projected covert hidden image, and full colour 3D holographic stereogram optical features. The latter feature, christened 3Digital, won the IHMA 'New Holographic Technique' award in 2000.*

*Right: A 45 x 45 mm brand authentication hologram for Texas Instruments Inc., USA.*

Whilst designing the two masks that controlled both grating orientation and spatial frequency, I realised that there was one final possibility. By arranging the apertures on each mask so that, at a single position, they overlapped to generate four beams of laser light rather than just two, all four beams would interfere to form six mixed-frequency gratings. This, in turn, would produce an achromatic, or white, diffractive pixel. The ability to create achromatic pixels was exclusive to the Lightgate system and a unique selling point, enabling the

creation of achromatic kinetic patterns, achromatic 3D stereograms, mixed white and coloured diffractive elements, and many other exclusive security features.



*The mask positions relative to each other for the selection of four beams.*

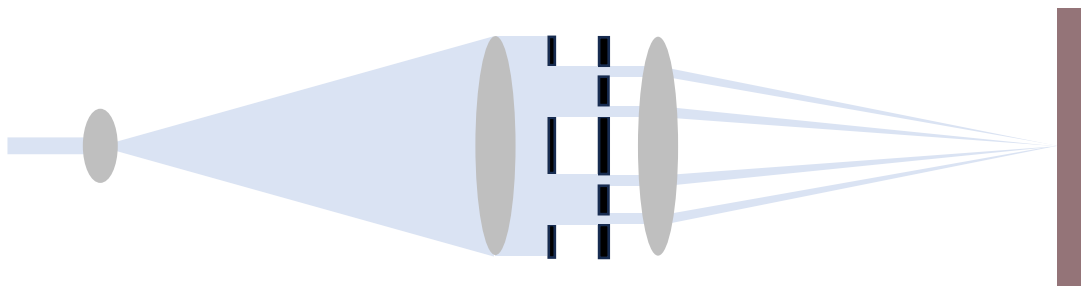

*A mask configuration that produces four beams for the creation of achromatic - white diffractive pixels.*



*Left: A Lightgate 4-beam achromatic logo on a rainbow kinetic background.*

*Right: Achromatic kinetic diffractive patterns made using the Lightgate four-beam technique.*

*One commercially successful use of the four-beam achromatic technique was to simulate the carbon-fibre pattern.*

A matt white 'diffuse' effect, often used for registration marks, could also be created by simply placing a piece of adhesive diffusion tape in contact with the photoresist plate prior to exposure. Diffuse pixels were created by exposing through the tape, which produced a microscopic random surface structure.

The Lightgate 1270 was the world's first fully computer-automated, light-based, dot-matrix mastering platform capable of producing sophisticated security holograms and wide-angle 3D stereograms, surpassing the conventional 'real model' and '2D-3D' techniques used at the time. Crucially, its exceptionally user-friendly but sophisticated design and exposure software, *Lightgate Control*, allowed operators with little or even no holography experience to create complex security holograms at the click of a button for the very first time.

The Lightgate 1270 used a 442 nm blue helium–cadmium laser, but in the early 2000s this was replaced by a small, far more convenient, less expensive, and longer-lived solid-state 405 nm violet-blue diode laser and the system was rebranded as the Lightgate B.

Between 1997 and 2006, over forty Lightgate 1270 and Lightgate B systems were sold worldwide, an exceptional penetration for what was, at the time, a relatively small security hologram industry.

In 1996, only a handful of large companies dominated the security hologram market, but the cost-effective, simple-to-operate, computer-automated Lightgate system enabled many smaller firms and start-ups, particularly in the Far East and Asia, not only to compete, but to produce superior, next-generation security holograms. The £98,000 Lightgate was, therefore, instrumental in the rapid expansion of the security hologram sector during the late 1990s and early 2000s, a period in which it grew into a billion-dollar industry.

The Lightgate platform then evolved through successive generations of dot-matrix mastering systems, the Lightgate S - an ultra-fast system, the Lightgate P - the world's first large format dot-matrix mastering system for seamless packaging applications, Lightgate X, Lightgate P-UV, Lightgate D, and most recently the Lightgate U system, introduced in 2025.

Billions of holograms have been produced from Lightgate 1270 and Lightgate B originated master holograms, including for some of the world's largest security hologram projects. Even today, three decades after its invention, original Lightgate systems remain in active use for security hologram mastering. Profits from the sale of my Lightgate 1270 systems and its successors sustained Spatial Imaging Ltd., supported the company's commercial hologram and lenticular work, funded artistic and display projects such as my own holographic portraiture, and paid the wages of its many employees.



*Lightgate dot-matrix holograms for the UEFA EURO 2000 Football Championships, used on all merchandise.*

The Lightgate system was followed by the KineMax system, developed by Pawel Stepien of Polish Holography Systems. The KineMax employed an equally innovative but fundamentally different digital mastering technology termed 'image matrix', and became the leading system from the mid-2000's until it too was surpassed by the truly groundbreaking PicoMaster platform, a single-beam, direct-write lithography (SB-DWL) system developed in 2013 by the Dutch company 4Pico B.V. (now Raith Laser Systems B.V.), and exclusively distributed worldwide by Spatial Imaging.

Whilst other systems have come and gone, such as the accomplished but commercially unsuccessful Sparkle system from Ahead Optoelectronics, Inc, a more refined and capable version of the Light Machine; the Firefly system from Combustión Ingenieros S.A.S., modelled on the KineMax image-matrix system; and various systems produced in China and India that replicated the original Light Machine, only three digital security hologram mastering platforms have dominated the market over the past thirty years: first, the Lightgate dot-matrix system; second, the KineMax image-matrix system; and third, the PicoMaster SB-DWL system.

My eureka moment, however, and the Lightgate 1270 system that followed, proved pivotal. It set in motion a transformation of the security hologram industry and reshaped its capabilities and competitive landscape.

N.B. At this point I will mention two papers written and published by C.K. Lee: the first, *Dot Matrix Holograms*, for *The Holography Marketplace 7th Edition*, November 1998, and the second, *Optical configuration and color-representation range of a variable-pitch dot-matrix holographic printer*, for *Applied Optics*, Vol. 39, No. 1, 1 January 2000. Both contain a good explanation of dot-matrix holography, but neither mention the Lightgate system in their surveys of available systems, even though the Lightgate, with full spatial-frequency modulation and full colour 3D capability, had been developed 18 months earlier and several systems had been sold. The omission was simply a consequence of my art-school background: to this day I have never written a formal technical paper and have seldom sought to publish patents or gain publicity for my technical achievements, as scientists and engineers are trained to do. As a result, those in Taiwan and elsewhere did not know of the Lightgate system or how it worked. A similar issue surrounded the invention of my DI-HO system, the world-first “digital” holographic stereogram printer in 1989–1991. In many fields, recognition of an achievement depends on publishing papers, patents, and articles. Without them, new and innovative developments are easily lost to the historical record.

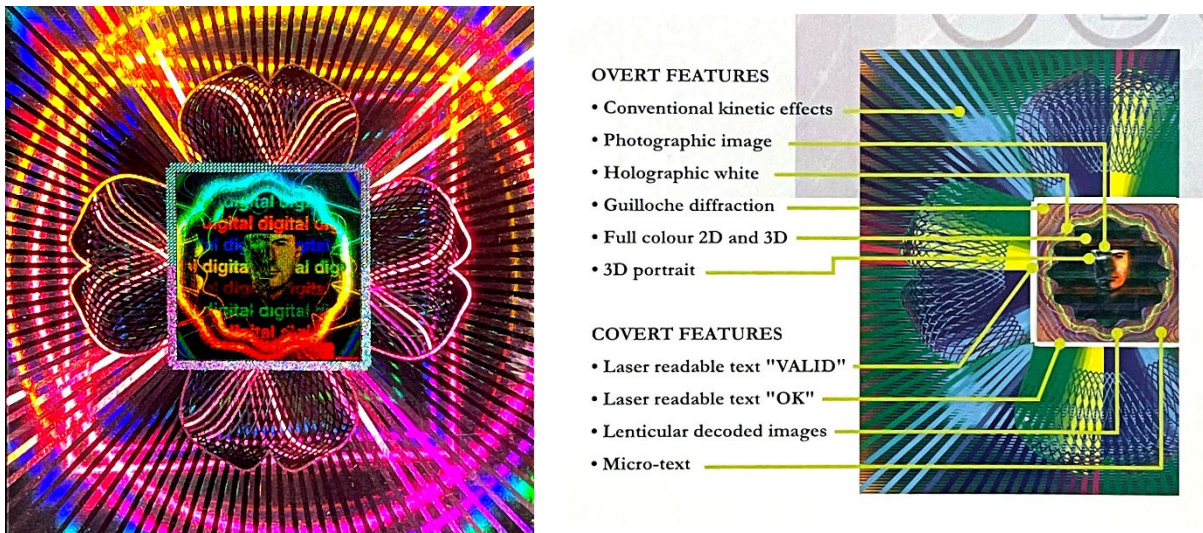

*A sample multiple-resolution Lightgate dot-matrix security hologram, 2002, incorporating the features listed on the left. At its centre is a 3Digital holographic portrait of Rob Munday. This may have been the first digital holographic portrait created using a 3D digital scan of a person's head. The resulting 3D data was then used to construct the computer model from which the stereographic image sequence was rendered.*

## Examples of prominent Lightgate dot-matrix holograms

### The Millennium Dome 2032 dpi hologram

In 1999, Spatial Imaging secured a commission from the London Millennium Dome to create three holograms, two security hologram to authenticate official Dome merchandise and a larger hologram to be applied to gift items. For such a landmark project, I set out to push the boundaries of the Lightgate still further. By adopting a shorter-focal-length focusing lens, I was able to produce an even higher-resolution dot-matrix hologram, achieving a fitting 2,000 dpi (actually 2,032 dpi) for the year 2000. Please note, 3,000 dpi resolution dot matrix holograms were ultimately achieved using the Lightgate 1270, and 4,000 dpi using later Lightgate systems.

15 mm and 20 mm diameter, 2032 dpi dot-matrix holographic stereograms, of a computer-generated model of the Millennium Dome, surrounded by dot-matrix text was produced using the Lightgate 1270. These holograms were the first commercially produced >2,000 dpi dot-matrix holograms, and they are also believed to be the first commercially produced dot-matrix security holograms to contain a full colour, digital dot-matrix holographic stereogram.

A third larger 25 mm diameter hologram was also produced using a DI-HO digital holographic stereogram with overlaid dot-matrix text.



### Holographic security seals for Proctor and Gamble

Lightgate dot-matrix holographic security seals were commissioned by Procter & Gamble for their shampoo bottles distributed across South America. The project was secured after a one-hour meeting in Lima, Peru, for which I had expressly flown from London to Peru via Miami. The purpose was to curb the widespread practice of refilling and reselling discarded bottles. The design specified a single-colour 2D–3D background layer, over which text in a second colour and a four-beam achromatic logo were rendered on the hologram's surface. The project required the manufacture of millions of tamper-evident holograms, produced by Crown Roll Leaf Inc. in New Jersey, USA, which were supplied directly to P&G on a rolling three-month schedule.



### Lightgate hologram portrait miniatures of Queen Elizabeth II

Perhaps the most notable Lightgate dot-matrix holograms, made using my award-winning 3Digital holographic stereogram technique, were created by me using my Lightgate B system in 2004 and 2005. These works were the first and second hologram portrait miniatures of the late Queen Elizabeth II, or of any British monarch, and are believed to be the world's first digital dot-matrix hologram portrait miniatures, and perhaps even the first-ever hologram portrait miniatures.

In 2003, I was commissioned to shoot and create the first officially commissioned 3D holographic portrait of Queen Elizabeth II and in doing so became the first, and to date the only royal holographer. The project was a joint creative collaboration with my former agent, designer, and now artist, Chris Levine, undertaken for the Jersey Heritage Trust to commemorate the Island of Jersey's 800-year allegiance to the English Crown. The final commissioned work was a large-format lenticular stereogram; however, between two sittings at Buckingham Palace, in February 2004, I created the first portrait miniature especially to show the Queen at the second sitting in March 2004.

The second portrait miniature - the first achromatic miniature - was created in December 2005. It was later gold-coated and unveiled to great acclaim at the Royal Miniature Society's annual exhibition at the Mall Galleries, London, in 2013. Elizabeth Meek MBE, President of the Royal Miniature Society, and the Rt. Hon. Michael Portillo, Chairman of the Federation of British Artists, described the work as "extraordinary and spellbinding" and "the future of portrait miniatures." A third portrait miniature was produced in 2011, again using my Lightgate B system, for the Island of Jersey's Diamond Jubilee postage stamp, the first stamp in the world to contain a 3D holographic portrait of a Head of State, and the first to feature a black-and-white achromatic hologram.

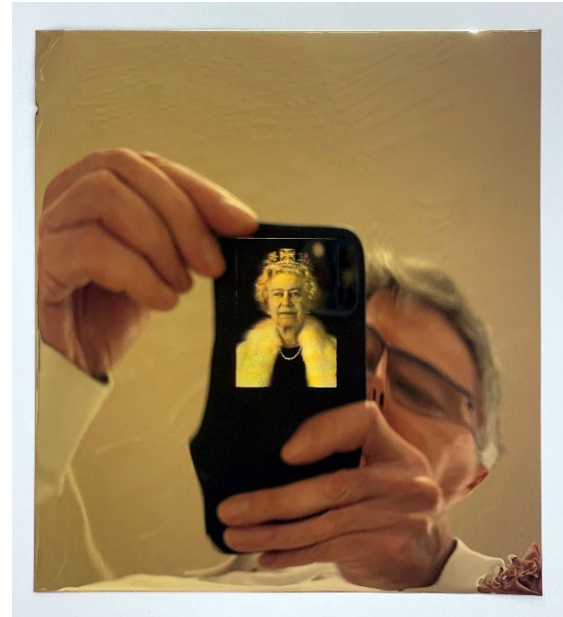
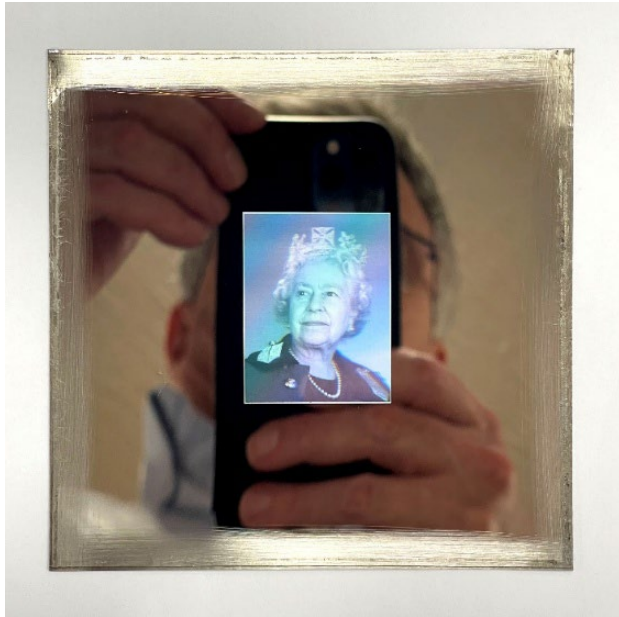

Left: The first digital dot-matrix hologram portrait miniature of Queen Elizabeth II, 2004.  
 Right: The second digital dot-matrix hologram portrait miniature, the first achromatic portrait miniature, and the first gold portrait miniature of Queen Elizabeth II, 2005/2013.



<p>Sheet of four The two se-tenant sets <b>£8</b> embossed and spot-varnished <b>£4</b></p> <p><b>The Queen's Diamond Jubilee</b> Issue date: 1 June 2012</p> <p>'Equanimity' is the first official holographic portrait of Her Majesty The Queen and was created by artist Chris Levine and holographer Rob Munday. Our £10 stamp re-creates the portrait in holographic form using a unique black and white digital hologram miniature, thought to be the first of its kind in the world, created by Rob Munday at his studios in London.</p> <p>Single stamp <b>£10</b>        Sheet of four stamps <b>£40</b>        First Day Covers and Presentation Packs <b>£11.10</b></p> 	<p><b>Jersey Post</b></p> <p>Philatelic Design &amp; Marketing        Goose Green Marsh        JERSEY        JE1 1FH        T +44 (0) 1534 616634        F +44 (0) 1534 616330  <a href="http://www.jerseystamps.com">www.jerseystamps.com</a></p> <p>Dear Rob,        Thank you so much for all your help &amp; support in making our £10 hologram stamp the best Jersey Stamp we've ever issued!        With Compliments        Kind Regards Sally</p> <p><small>Registered Company number: 8334        Registered Office: Postal Headquarters, La Rue Grenville, La Rue des Press Trading Estate, St Saviour, JERSEY, JE2 7QS        Jersey Post is a trading name of Jersey Post Limited. Jersey Post Limited is licensed and regulated by the Jersey Competition Regulatory Authority for the provision of postal services and by the Jersey Financial Services Commission for the provision of Money Service Business. Part of the Jersey Post Group</small></p>
--	--

The third digital dot-matrix hologram portrait miniature of Queen Elizabeth II, 2011, for the Island of Jersey's Diamond Jubilee postage stamp, the first stamp in the world to contain a 3D holographic portrait of a Head of State and the first to feature a black and white 'achromatic' hologram.



*The Lightgate 1270, 1997, utilising a 442nm helium cadmium laser.*

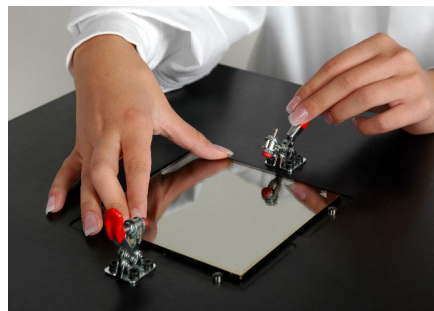
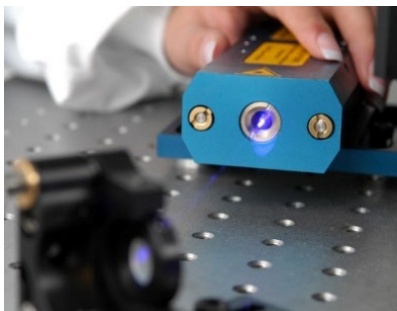

*Left: Close-up of the Lightgate B System, 2004, utilising a 405nm diode laser. Right: Loading a photoresist plate.*

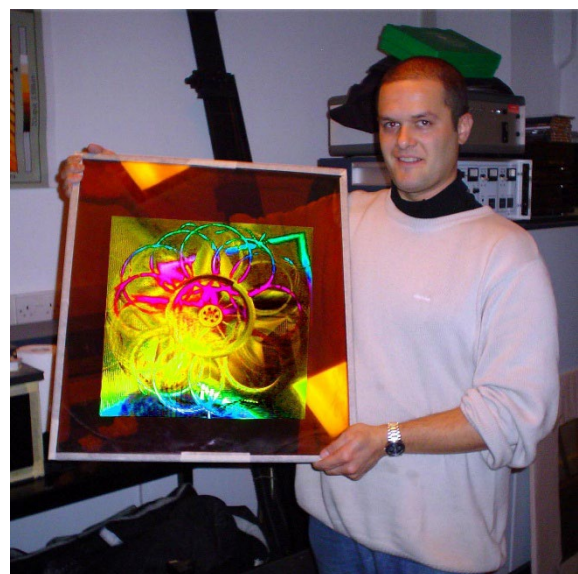

*Left: The Lightgate P1 large-format system, 2002, also known as the Lightgate Extreme. Right: A large-format dot-matrix hologram made using the Lightgate P1 held by Spatial Imaging holographer Olivier Pitavy.*

## The next-generation Lightgate S and Lightgate P systems featuring LightSpeed technology

In 2005, after eight years of highly successful sales of the Lightgate 1270 and Lightgate B systems, I set myself another challenge. Smaller-format dot-matrix had performed very well commercially, but no digital hologram mastering technology of any kind existed that was fast enough to produce high-quality, high-resolution, large-format, seamless holograms for packaging applications. I had built the medium-format Lightgate P1, capable of making holograms up to 600 x 600 mm (24" x 24") in size, but it took a very long time to make such holograms. At that time, large area diffractive patterns for packaging, product enhancement, interior design, and architectural use were created by tiling a small hologram edge-to-edge. This approach inevitably introduced visible joins, an unacceptable flaw for packaging manufacturers who wanted uninterrupted, seamless imagery across their products.

The only true solution was to originate a single, large-format hologram, but with existing systems running at only a few hundred pixels per second, producing a master of that scale would have taken weeks - commercially unviable by any measure. I therefore set out to invent a system capable of exposing holograms up to, and even exceeding, 1 x 1 metre in just two to three days, transforming what had previously been impossible into a practical, production-ready process. This required exposing not hundreds of pixels per second, but thousands!

An idea first took root through a conversation with Jeffrey Wyle of Light Dimensions Inc. in Miami, owned by Kevin Brown. Jeffrey had been developing a higher-speed dot-matrix mastering system that utilised rotating dove prisms in the two legs of a Mach-Zehnder interferometer, and he flew to London to explore the concept with me. Although ingenious, that optical approach proved unsuitable for the speed and precision I needed. More importantly, my aim was to devise a completely original method, one that avoided replicating existing technologies and opened a genuinely new pathway for large-format digital hologram mastering.

The interferometer concept, however, was compelling and so I began to explore it more deeply. Scanning a beam through an interferometer causes the two emerging beams to move together while remaining superimposed. My idea was to find a way to invert one of those two beams so that it became the mirror image of the other, opposite and perfectly symmetrical about the optical axis. Achieving that symmetry would unlock a fundamentally new method of generating dot-matrix holograms at high speed.

The turning point came in a brief but pivotal meeting. I arranged to see Prof. Paul French from the optics department at Imperial College, London and put the above challenge to him. His response was immediate: "a 4F-8F system."

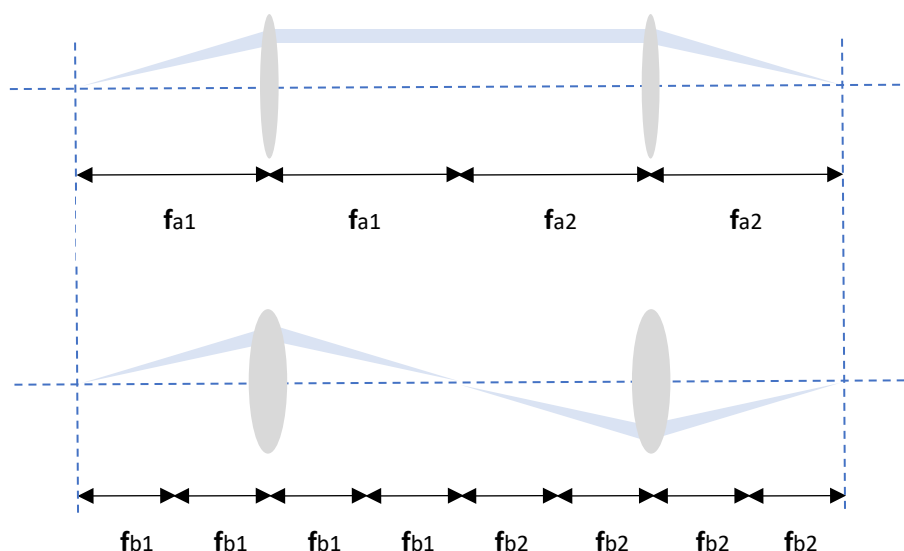

*The standard 4F – 8F optical system.*

A 4F–8F imaging system is essentially an asymmetric arrangement of lenses placed on either side of the interferometer, whereby the input and output images for each arm, in this case a point of light, are equal but opposite to each other.

On the first arm, two lenses of equal focal length are arranged so that the input image lies exactly one focal length in front of the first lens, and the output image is formed exactly one focal length beyond the second lens. The lenses themselves are separated by two focal lengths, giving a total optical path of four focal lengths. This configuration produces a collimated beam between the lenses, parallel to the optical axis, and yields an inverted image at the output. On the opposite arm, two lenses are again used, but with half the focal length of those in the first arm. In this case, the input image lies exactly two focal lengths before the first lens, and the output image is formed exactly two focal lengths after the second lens. The lenses are separated by four focal lengths, giving a total path length of eight focal lengths. This arrangement causes the beam to cross the optical axis between the lenses and produces an upright output image. This creates the symmetry required for the idea to work. I named it the ‘scanning interferometer’ dot-matrix method.

As shown in the diagram below, the first incarnation of my scanning interferometer used a narrow but expanding beam from a point source directed through a Mach-Zehnder interferometer optical system. This single input beam arrives at the far end as two output beams on opposite sides of the optical axis which refocus and recombine at the output image plane to create a focussed point of interference.

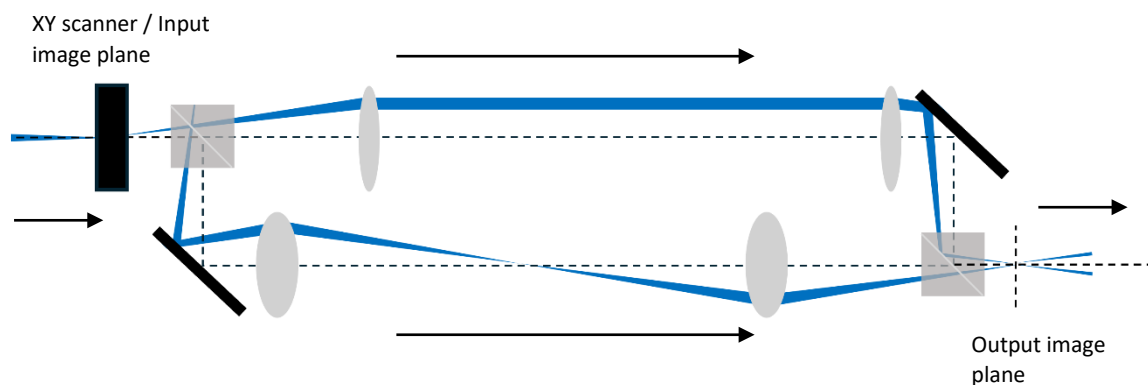

*A scanning Mach-Zehnder interferometer based on a standard 4F-8F optical system.*

A prototype was built and tested, but it quickly revealed a fundamental limitation. The optical configuration produced two extremely small focal points at the output image plane, and achieving perfect overlap between them, especially when rotating the beams, was extraordinarily difficult. This constraint ultimately rendered the standard 4F-8F configuration unsuitable for a high-speed, scanning interferometer mastering system.

It therefore fell to me to devise another solution. The approach I developed was to scan a collimated beam through a revised lens arrangement. Instead of beginning with a narrow, diverging point-source beam, the input would now be a uniform circular collimated beam - typically 2 - 4 mm in diameter. This arrangement generated two corresponding collimated output beams at the far end of the system. Crucially, these two beams would once again converge and interfere, but without the impossible alignment demands of the earlier point-focus design. A further advantage was that the relatively large overlap region could be easily masked to provide a square, or any desired diffractive pixel shape.

The 4F arm of the interferometer remained unchanged, but the 8F arm required a different strategy. Instead, I used four sequential 2F imaging sections, each employing lenses with half the focal length of those in the 4F arm. This configuration delivered the output beam inversion required.

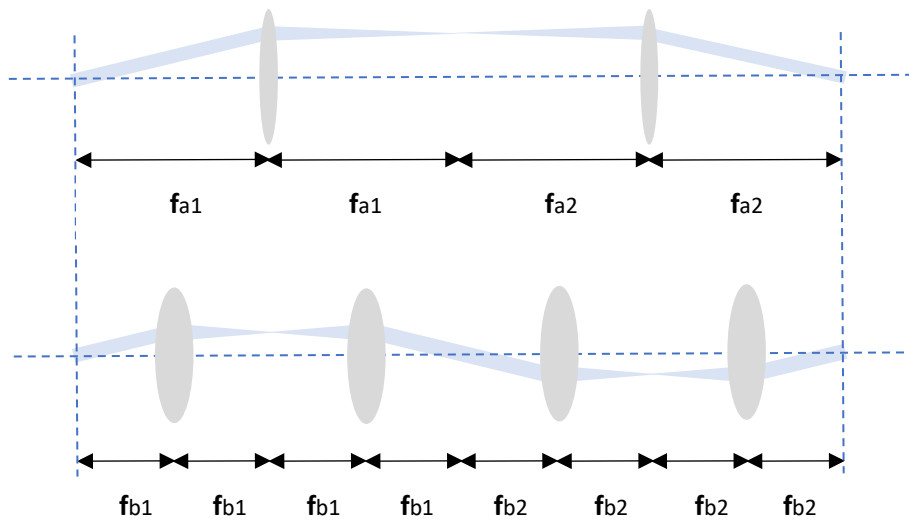

*An alternative 4F-8F optical design.*

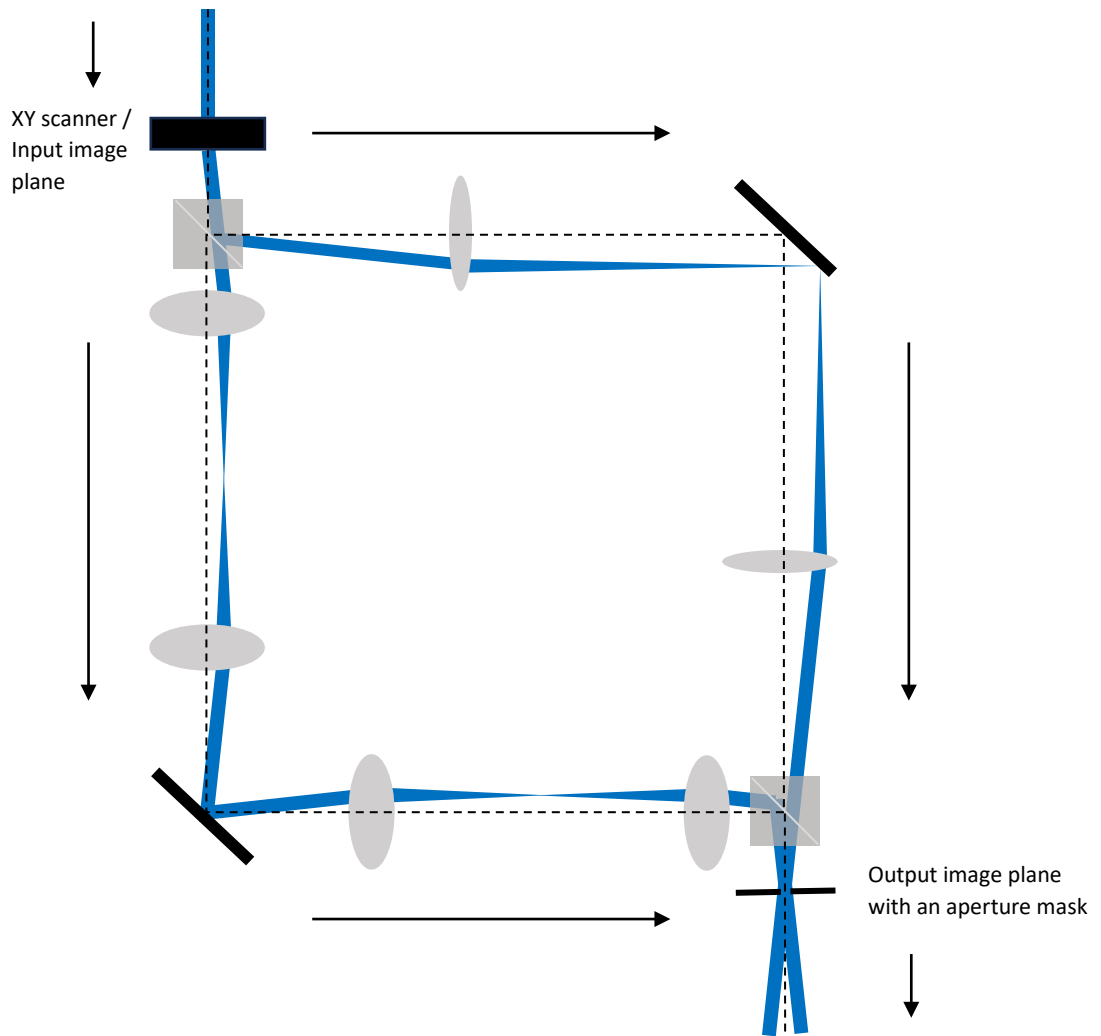

*A scanning Mach-Zehnder interferometer based on an alternative 4F-8F optical design.*

Because the previous layout lacked the compactness required to fit neatly underneath the open frame XY table of a Lightgate S system, or within the moving optical head of a Lightgate P system, I subsequently devised a more compact Michelson interferometer-based design, see *Patent Applications* below.

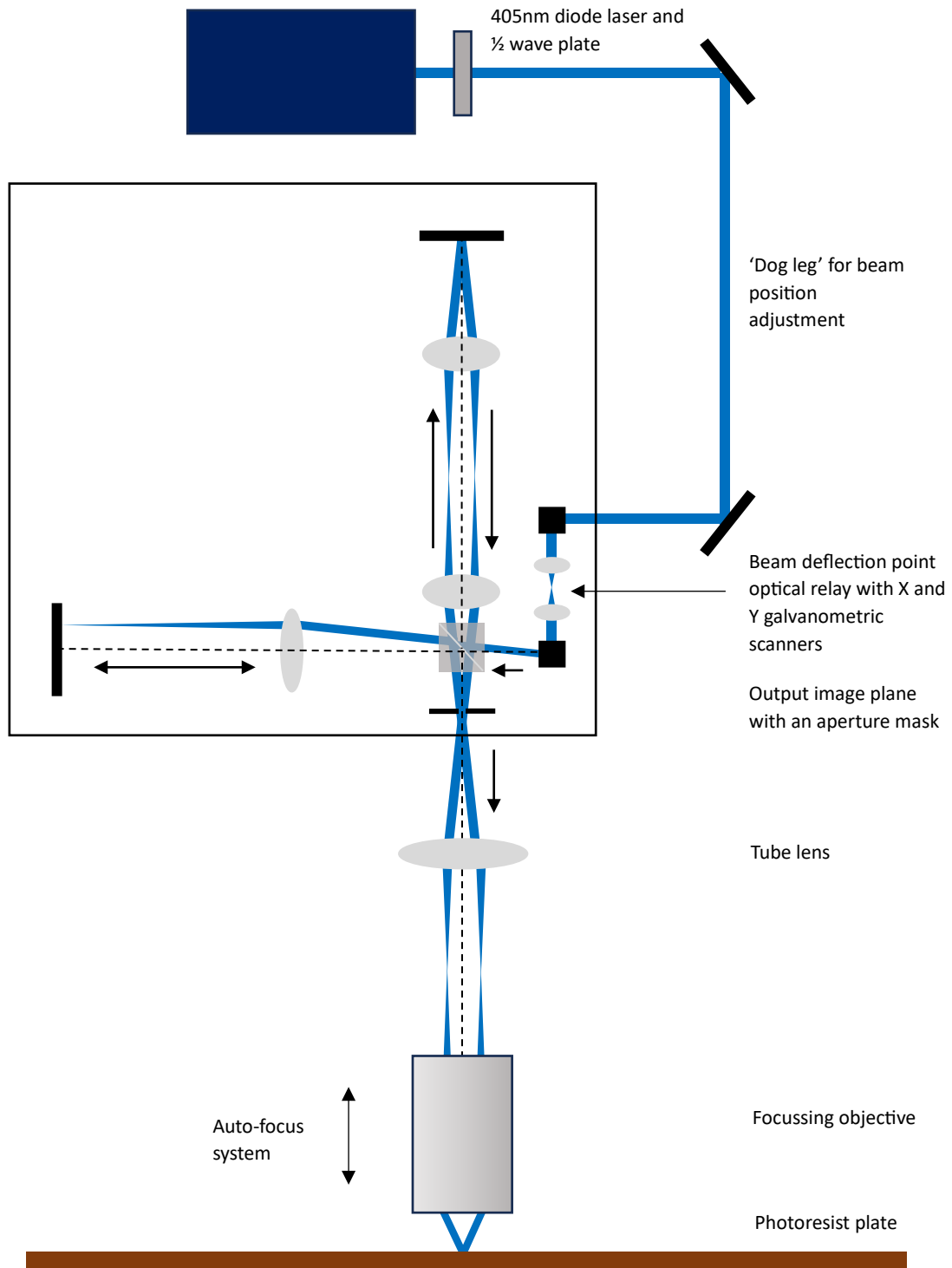

*The complete scanning interferometer system used for the ultra-high speed Lightgate S1 and Lightgate P2 dot-matrix mastering systems. In some configurations, beam-expansion optics were added to increase the input diameter, and a through-the-lens red-laser autofocus system was developed to maintain output image sharpness to within a few microns.*

The Lightgate systems that employed this version of my scanning-interferometer technology included the Lightgate S1, small to medium-format security hologram mastering system, as well as the large-format Lightgate P2 system for holographic packaging and other large-area holographic applications.

A final scanning-interferometer configuration, the subject of my fifth patent application, replaced the complex 4f–8f lens arrangements. The system utilised two right-angle - Porro prisms, one rotated 90 degrees relative to the other, positioned at the ends of each arm of a Michelson interferometer. This approach achieved the same goal but with far greater simplicity. This final configuration became the standard architecture for all Lightgate S2 and Lightgate P3 systems.

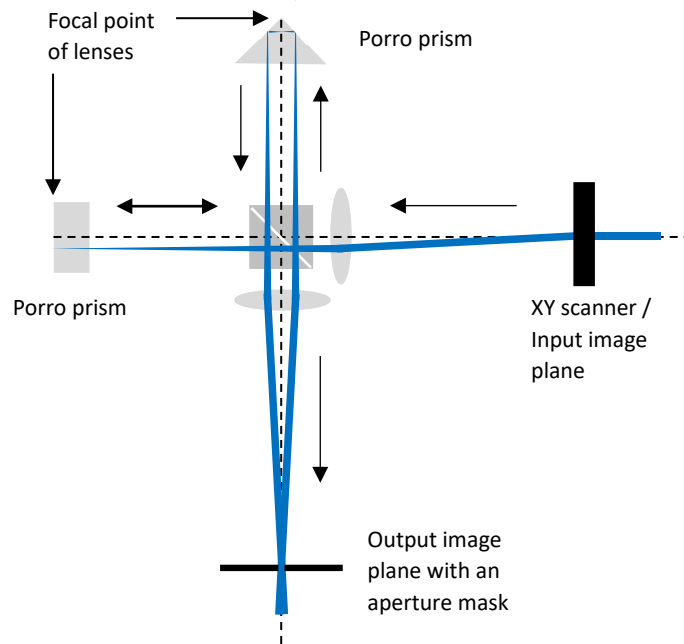

*The porro prism scanning interferometer used for all Lightgate S2 and Lightgate P3 dot-matrix systems.*

A further miniaturised variant bonded the lenses and prisms directly to a cube beamsplitter, producing a scanning interferometer that offered considerable promise for desktop dot-matrix hologram printers. Yet the wider failure of holography to gain a lasting foothold in consumer and educational markets meant that the potential of a small, affordable dot-matrix hologram printer was never realised.

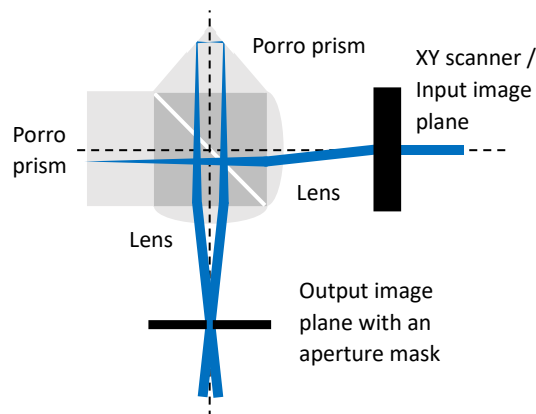

*A miniaturised right-angle prism scanning interferometer proposed for desktop dot-matrix hologram printers.*



*Rob Munday with his Lightgate S2 dot-matrix mastering system.*



*Left: The Lightgate S2 control units, top, the galvanometric scanner and laser controller, and bottom, the Aerotech motion control system. Right: The Lightgate S system in operation.*



*Rob Munday with his Lightgate P3 system, circa 2008, for a Chinese company called Dongnan, Shantou, China.*



Holographer Brian Mentz operates a large-format Lightgate P3 system at the premises of Vacumet Corp, Franklin, Massachusetts, USA.

## Direct Laser Etching

In 2010, I conceived the idea of bypassing the interferometer entirely and directing a single beam of laser light straight through the focusing objective to create a single, tightly focused spot of light. This focused beam was then used to generate a new type of *Direct Laser Etched* optical feature, a low-spatial frequency diffractive image that appeared achromatic or silver-white when viewed.

Lightgate Control first calculated and saved the positional data for arrays of linear vectors for any 8-bit greyscale bitmap image, varying the vector spacing and/or vector orientation according to the grey level. These vectors were then directly written onto the photoresist using the stationary focused laser beam in combination with the fast linear-motor XY stages of the Lightgate system. After development these periodic grating structures were in the order of 2 - 4 um wide and 1 – 2 um deep.

The Lightgate platform was the first light-based hologram mastering system to offer this technique, later followed by the KineMax system. It proved particularly effective for producing silver-metallic diffractive images and patterns. This technique also forms the basis of Spatial Imaging's large-format Lightgate D system.

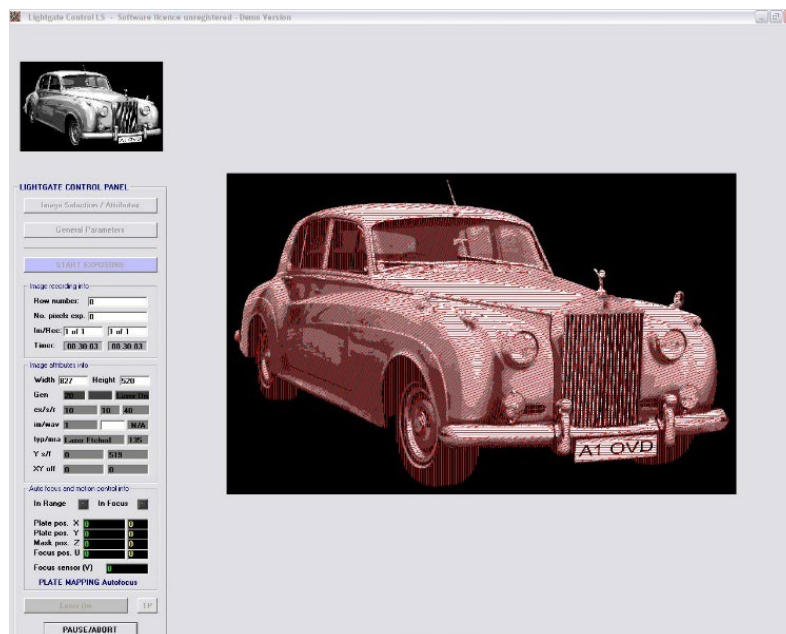

*The Lightgate Direct Laser Etch feature in Lightgate Control, showing a greyscale image of a Rolls Royce after vectorisation.*

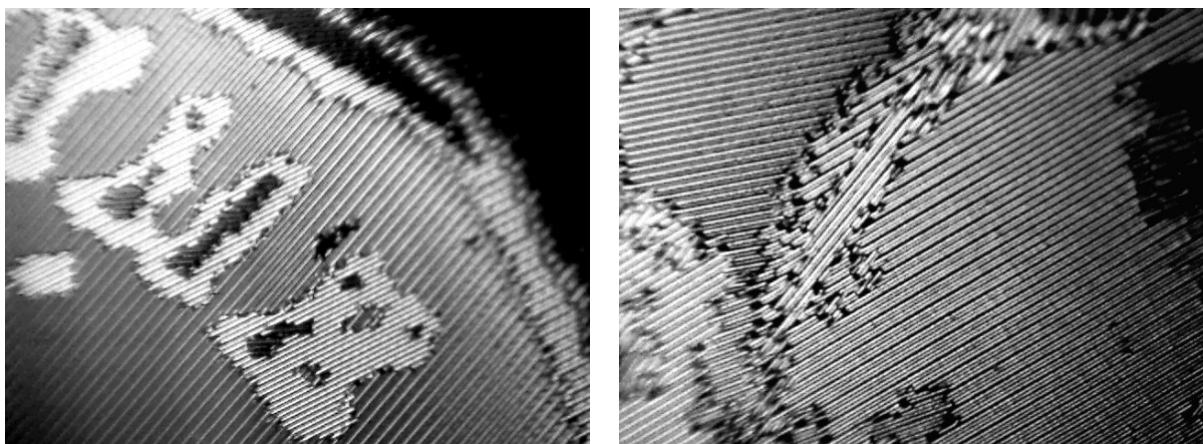

*Close up photographs of a Lightgate Direct Laser Etched image, in this case a British 50 pence coin.*

## Lightgate software and new holographic techniques

**Lightgate Control**, the software I began writing in 1996, provides a complete environment for the design, composition, visualisation, and automatic exposure of complex multi-element dot-matrix holograms, including full optical recombination. Holograms can be composed of an almost unlimited number of optical elements, each with its own set of unique holographic variables. Written using Microsoft's VB.net, the program has been continuously enhanced for three decades and was the most capable hologram-mastering software available on any platform until the arrival of *PicoHLD* for the 4Pico B.V. PicoMaster system in 2022.

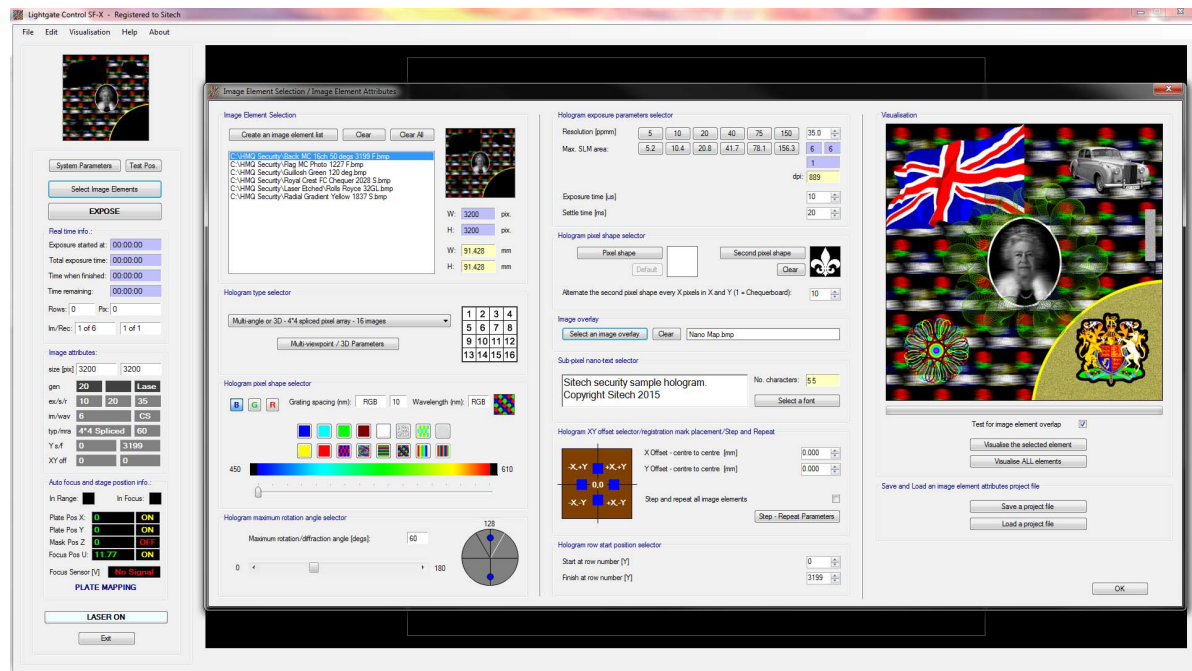

*Lightgate Control, circa. 2018.*

Between 1996 and 2004, and using the unique capabilities of the Lightgate system, I also developed many new and innovative holographic techniques and optical features. These included *3Digital*, in 1997, a method to create full colour and achromatic, directly written, 3D dot-matrix holographic stereograms with wide-angle parallax, and *LPI*, in 1998, a technique to produce dot-matrix laser projected covert hidden images (LPI).

**3Digital** - The process of creating a 3Digital hologram began by first choosing a stereographic image sequence. The image sequence is then post-processed to remove the various image distortions inherent in such sequences, such as keystone distortion and scale distortion. Each image in the sequence is registered to a common point, and all the usual creative variables of composition, contrast, sharpness, etc., are adjusted.



From the post-processed stereographic image sequence only sixteen equally spaced images are required. These sixteen images are then combined using custom-written software to form a single image utilising a process known as interlacing. For example, the first pixel in each of the 16 images is combined to form a 4 x 4 pixel array. This is repeated for the second pixel and so on. The final interlaced image, therefore, contains every pixel from all sixteen source images/viewpoints, arranged as shown below on the left.

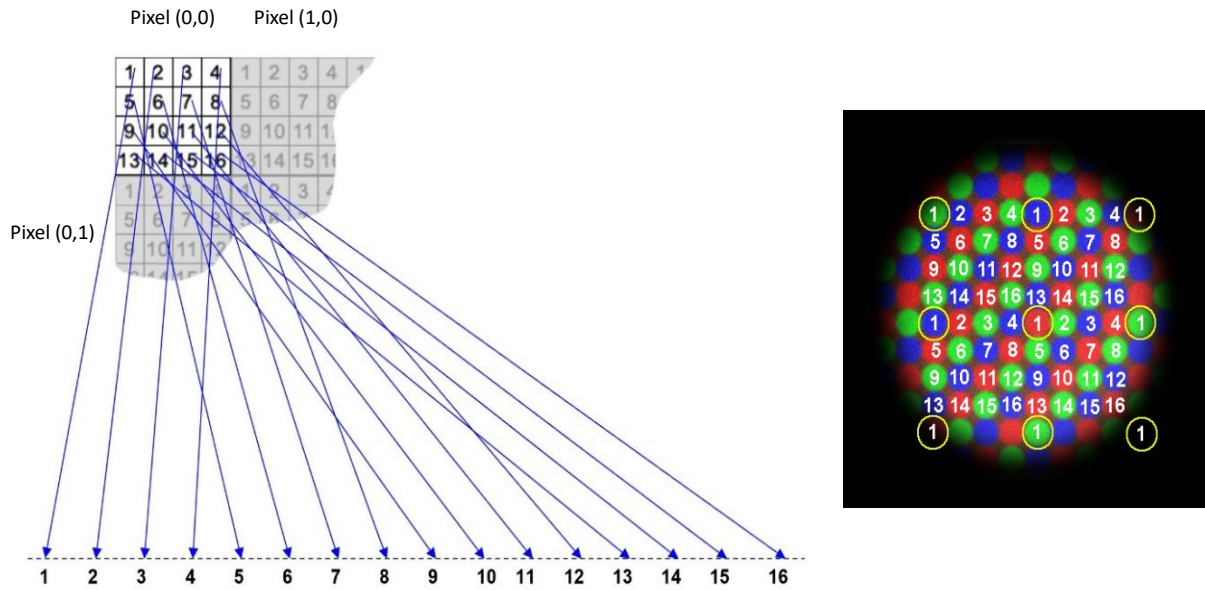

Left: A sixteen-image - 4 x 4 diffractive pixel array, producing sixteen stereographic viewing zones in space.  
 Right: The RGB grating frequency pattern used for full colour and achromatic holograms.

A holographic stereogram is then made by automatically recording each pixel of this interlaced image, one by one, on a light-sensitive photoresist plate. The angle and spatial frequency of each diffractive pixel's diffraction grating is optimized to redirect incoming light to a specific location in space and with a particular intensity. This controlled redirection of light results in the formation of a three-dimensional holographic stereogram image.

For a single-colour rainbow hologram, such as the first holographic portrait miniature shown above, every diffractive pixel in the hologram is made to contain a diffraction grating with the same spatial frequency. For an achromatic hologram, such as the second holographic portrait miniature shown above, the diffractive pixels recorded contain diffraction gratings with three different spatial frequencies, corresponding to red, green, and blue colours, arranged in a suitable pattern. The pattern, shown above on the right, of red, green, and blue pixels, when combined with a 16-viewpoint / 4 x 4-pixel array, ensures that each viewing zone contains all three colours and hence will merge to produce a full colour or achromatic-black and white holographic image.



Achromatic and full colour 3Digital dot matrix holographic stereograms made for Topps Spiderman trading cards and promotional use using the Lightgate B system.

In the year 2000, I was awarded the coveted *International Hologram Manufacturers Association 'Excellence in Holography - Best New Technique'* award for my 3Digital technique.

**LPI** - A new form of still or animated laser-projected covert hidden image and optical security feature, that I developed in 1998, thought to be the first of its kind to be produced using a digital dot-matrix mastering system. The feature was created by forming an array of diffractive pixels, each calculated and recorded to direct light to a single point in 3D space at a defined distance from the hologram. When the full pixel array is illuminated with a laser, these points combine to form a complete image or word suspended in space, which can also be projected onto a viewing screen. A further variation involved randomising the position of each diffractive pixel within the array, disguising the LPI as a much more common graphics 'sparkle' effect. The area in which an LPI can be stored can be very small, less than 200 microns square, or cover the entire hologram.

Since 1998, laser-projected hidden images of this type have been widely adopted and now appear on almost all document-security and brand-authentication holograms mastered using digital dot-matrix, image-matrix, and the latest direct-write-lithography systems. Animated LPI's, such as flying birds, are particularly effective.

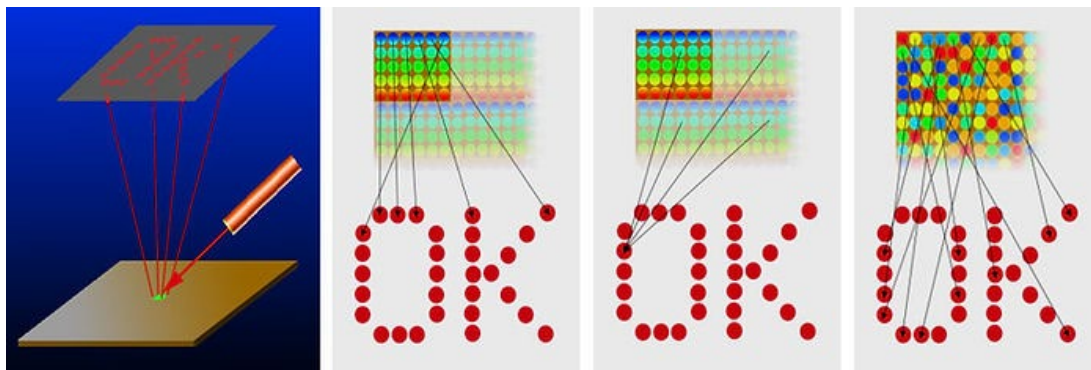

*The Lightgate Control LPI feature.*

Alongside the development of the LPI feature, Spatial Imaging also introduced an LPI-reading device known as the *Authenticator*. This handheld unit incorporated a small red diode laser and enabled quick, reliable visual identification of LPI features embedded within security holograms. When an LPI image was present, the corresponding text or graphic appeared on the display. The Authenticator also included an illuminated magnifying lens, allowing users to inspect microtext and micro-image elements within the hologram. Many hundreds of Authenticators were sold.

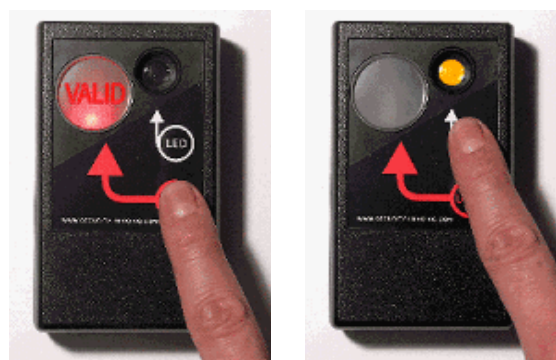

*Left: The Authenticator's LPI reader. Right: The Authenticator's micro-text / micro-image illuminated viewing lens.*

N.B. Ahead Optoelectronics, Inc. filed a patent for this technique in 1999, which was published in 2002 - US 6,392,768 B1.

## The Lightgate Pattern Maker

The *Lightgate Pattern Maker*, as the name suggests, was designed and written by me to computer-generate unique diffractive patterns, up to 1 x 1 metre in size, for security imaging and holographic packaging applications. Pattern families include shape/image patterns, line patterns, gradient patterns, and lens patterns. The software enables the mixing of all pattern types with masking, and animated visualisation under different lighting conditions. Once a pattern is finalised, it is output as a greyscale bitmap ready for recording.

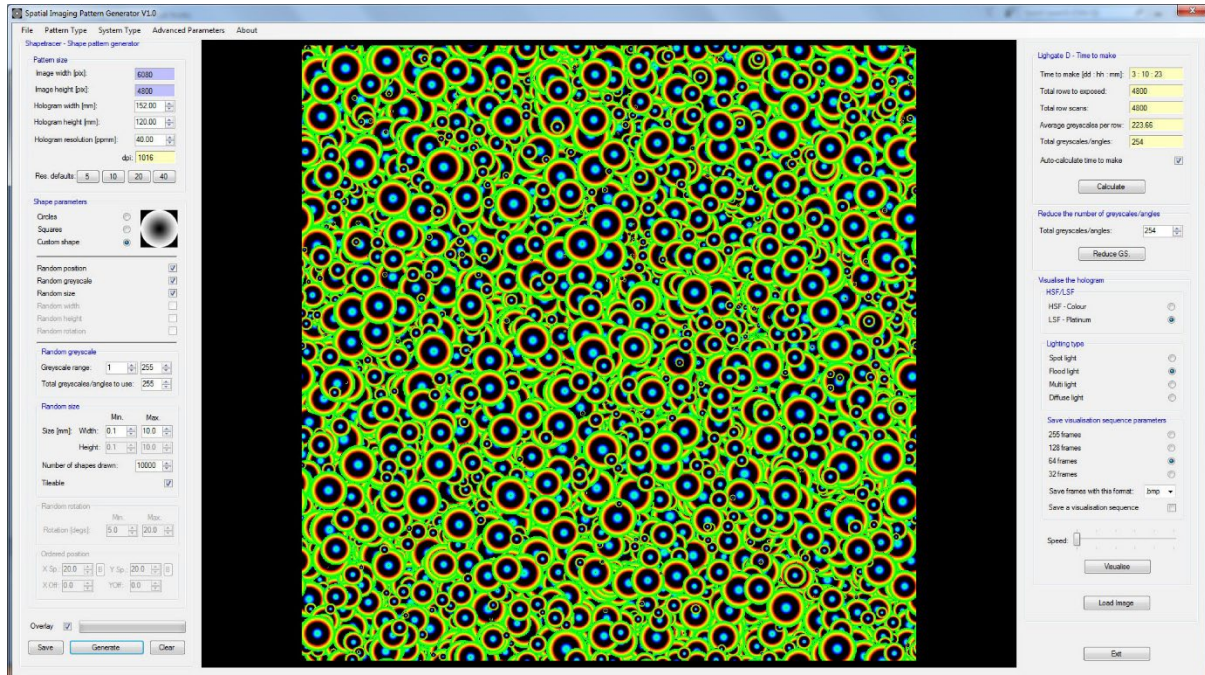

The *Lightgate Pattern Maker* showing a kinetic visualisation of a seamless random pattern created using a custom image.

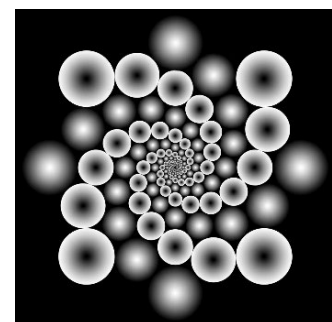
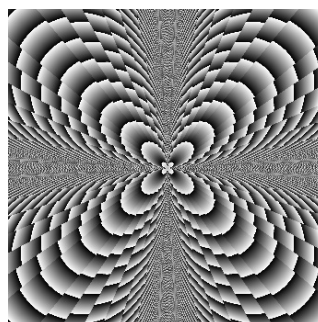
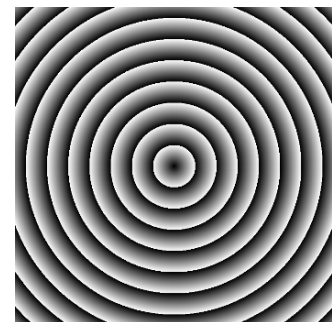
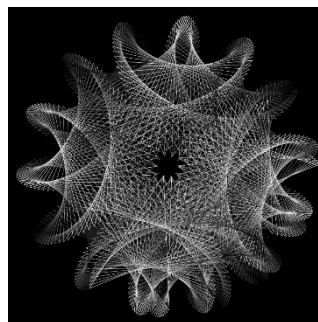

Left: An early promotional poster. Right: Example line, gradient, and lens patterns.

## PRISM

*PRISM - PaRallax Image Sequence Manipulator* - is a software program that I designed and wrote to handle the demanding image-processing tasks required for manipulating the stereographic and animated image sequences used in recording holographic stereograms and animated holograms. It provides an integrated suite of functions: automatic correction of keystone and other geometric distortions; sequential cropping to adjust perceived image-plane depth; frame-to-frame registration; frame interlacing; and batch copying and renaming of files and image sequences. It also incorporates on-screen stereographic visualisation, supporting multiple 3D display methods including anaglyphic rendering and output to 3D monitors and television systems.

PRISM is thought to be the first software specifically written to remove keystone distortion from digital stereographic image sequences. I wrote the first version in 2004 to correct the keystone distortion present in my digital stereographic image sequences of the late Queen Elizabeth II, a step that significantly improved the dimensional fidelity and visual appearance of the final 3D holographic portrait.

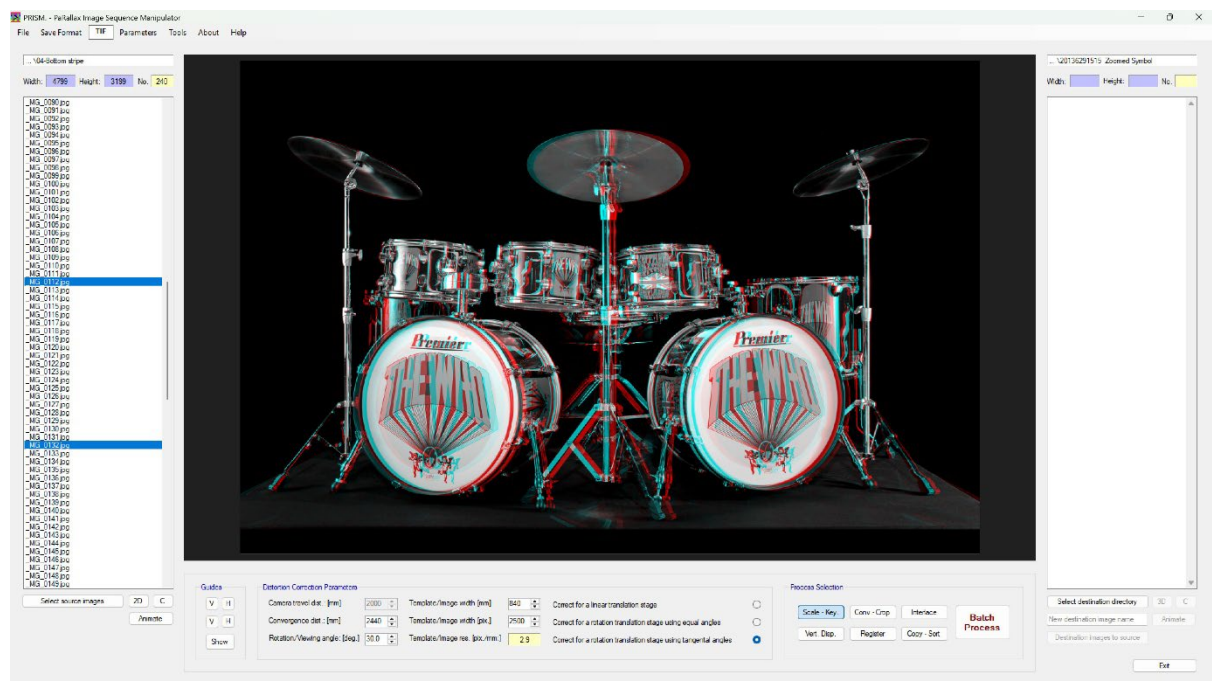

*PRISM showing a 3D anaglyphic image for on-screen 3D visualisation.*



*PRISM's automatic keystone distortion removal.*

*The upper set of images shows an uncorrected sequence, and the lower set of images shows a corrected sequence.*

## Patent Applications

I filed five dot-matrix related patent applications over a ten-year period.

1. **A METHOD AND APPARATUS FOR CREATING HOLOGRAPHIC PATTERNS** - WO1998029767 / PCTGB9703563 - Priority date: 4<sup>th</sup> January 1997.
2. **A METHOD AND APPARATUS FOR CREATING HOLOGRAPHIC PATTERNS** - PCTGB9809214.1 - Priority date: 30<sup>th</sup> April 1998.
3. **AN OPTICAL DEVICE, AN OPTICAL SYSTEM AND A METHOD OF MANUFACTURING A HOLOGRAPHIC OPTICAL ELEMENT** - WO2006003457 / PCTGB200502662 - Priority date: July 7<sup>th</sup> 2004.
4. **A HOLOGRAM AND ITS METHOD OF MANUFACTURE** - PCT/GB2006/OO1039 – Priority date: 23<sup>rd</sup> March 2005.
5. **IMPROVEMENTS IN OR RELATING TO OPTICAL SYSTEMS AND DEVICES** - WO2008025999 / PCTGB2007003314 - Priority date: 1<sup>st</sup> September 2006.

All of the above applications were ultimately allowed to lapse before grant. For a small company of three to six people, and with no effective protection in the Far East, the cost of patenting the technology was prohibitive. Instead, I chose to keep the system as private as possible and continually upgrade both the hardware and the software faster than it could be copied. This strategy was reinforced by selling systems to security-sector clients who operated under their own strict confidentiality regimes. The approach proved effective as no copies of any Lightgate systems have even been found.

### 1. METHOD AND APPARATUS FOR CREATING HOLOGRAPHIC PATTERNS

My first patent application was written in the autumn of 1996 and filed on 4<sup>th</sup> January 1997. By December 1996, I had already begun to devise ways of changing the angle between the beams and thus the grating spatial frequency on the fly. One such idea was to use a single, static electronically addressable mask in the form of a liquid crystal display however the lack of contrast of available TFT LCD screens made this idea unusable. Instead, I updated the initial application to include a physical mask / LCD combination. The physical mask would have slots instead of holes and these slots would be masked and modulated by the LCD screen. This idea also proved suboptimal due to the diffraction and scattering of the laser light through the LCD screen leading to multiple focal points at the output plane. Whilst this limitation was largely overcome by placing a mask close to the recording medium, the LCD approach was soon superseded by the far more efficient and elegant use of two physical masks, as described above, shortly after the patent application had been filed.

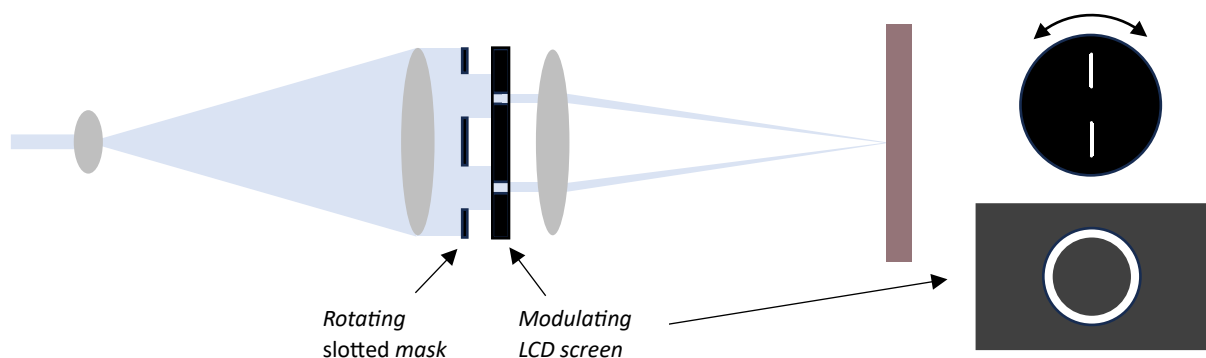

*Use of an LCD screen / SLM to modulate the light from the first slotted mask.*

## 2. A FASTER METHOD AND APPARATUS FOR CREATING HOLOGRAPHIC PATTERNS

Another improvement, made by way of my second patent application, filed on 30<sup>th</sup> April 1998, was a method for recording multiple diffractive pixels with a single exposure by pairing a microlens array or fibre-optic bundle with an LCD modulator at the input image plane. The microlens array or fibre bundle would generate multiple overlapping focal spots at the output plane, while the LCD modulator would selectively transmit only those pixels sharing the same diffraction grating orientation and spatial frequency, blocking all others. The LCD could also be used to modulate the brightness of each pixel individually. This multi-lens adaption was never implemented, however, and although technically promising, this patent application ultimately lapsed for financial reasons.

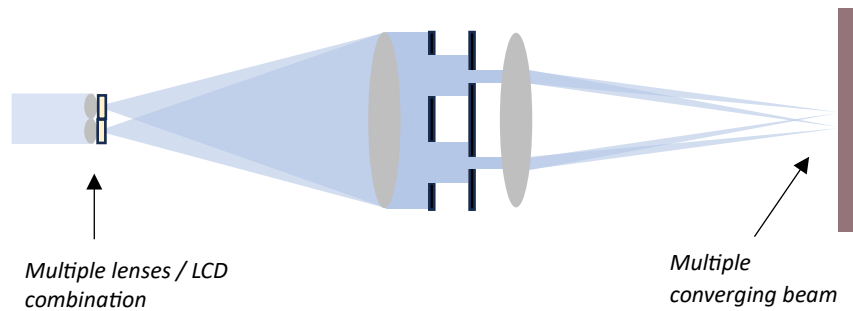

*A multi-lens / LCD Lightgate system – shown here with only two lenses for simplicity.*

## 3. AN OPTICAL DEVICE, AN OPTICAL SYSTEM AND A METHOD OF MANUFACTURING A HOLOGRAPHIC OPTICAL ELEMENT

See the section: *The next generation Lightgate S and Lightgate P systems with LightSpeed technology* for a description of the ultra-high speed scanning interferometer technology covered by this patent application.

## 4. A HOLOGRAM AND ITS METHOD OF MANUFACTURE

My fourth patent application, filed on 23<sup>rd</sup> March 2005, described a method to create a hybrid 3D holographic stereogram using conventional ink printing.

From the outset of dot-matrix holography, first conceived in 1984 by Frank S Davis, it was clear that each dot, or diffractive pixel, in a dot-matrix hologram performed only two functions: it redirected a beam of light to a specific location in space, by changing the pixel grating orientation and spatial frequency, and it modulated the brightness of that beam of light, the latter by varying the grating contrast and/or the pixel size.

It occurred to me soon after making my first dot-matrix digital holographic stereogram in 1997 that it would be possible to make a dot-matrix holographic stereogram using a series of white images, i.e. images that contained no pictorial information at all. Each pixel in the resultant hologram would be of maximum size and contrast and act in the same way as a conventional dot-matrix stereogram, guiding the light from the appropriate pixels in the hologram to the correct viewing zones in space, but no tonal image would be seen. The tonal image / pixel brightness modulation would then be provided in a different way, and after the hologram was made. Rather than modulating the contrast and/or size of each pixel at the time of exposure, the brightness could instead be modulated afterwards by printing conventional ink onto each pixel to vary its contrast or by ablating each pixel with a focussed, high-speed scanning pulsed laser to change its size.

By employing this technique, I envisaged a rapid manufacturing process for full-colour 3D holograms, achieved simply by printing onto blank holograms. I demonstrated the principle by creating such a blank dot-matrix hologram and overlaying a film transparency containing the appropriate interlaced image data.

I then realised that the ink used could be electronic ink, a type of ink that can be made more or less opaque by the application of an electric field. In this way a security dot-matrix hologram on a credit card could be personalised, covert information such as micro-text, etc. added, or the 3D holographic image updated for a new one each time the user visited a cashpoint machine.

A final idea was to provide the greyscale data using an SLM, such as an LCD or LCOS display, thus providing a miniature 3D dot-matrix holographic stereogram display.

It was during this time that I also began to appreciate that this type of auto-stereogram, in fact any type of holographic stereogram, is really nothing more than a holographic lenticular or integral image, first invented over 100-years ago. In other words, instead of employing a refractive lens to redirect light from an interlaced image, a diffractive lens is used instead.

It should also be noted here that, as early as 1991, a patent had been granted to Edwina Orr and David Traynor of Richmond Holographic Research and Development Ltd., formerly Richmond Holographic Studios, for a 3D electronic display system that employed an analogue transmission hologram of a diffusion screen to redirect light to two positions in space. In other words, light was redirected from a 'blank' holographic diffuser to left and right eye viewing zones, with the image information supplied by placing a transmissive LCD screen in contact with it, on which was displayed an interlaced image.

As mentioned above, I had been so deeply focused on designing and making dot-matrix holograms for so many years, and on what I regarded as simply a new type of dot-matrix hologram, that the similarity between my idea and Edwina and David's idea did not occur to me until after I filed my own patent in 2005. My primary claim also concerned producing a hard-copy hologram rather than an electronic display. Sadly, my filing of the patent caused a serious rift with my former employers and friends, David and Edwina, who assumed I had copied their idea, a grievance that they still hold onto today. Ultimately, however, my application was not granted, and none of RHRD's patents resulted in a financial return.

## 5. IMPROVEMENTS IN OR RELATING TO OPTICAL SYSTEMS AND DEVICES

My final patent application, filed on 1st September 2006, described my last scanning interferometer development, a miniaturised scanning-interferometer configuration that used right-angle porro prisms at the ends of each leg of a Michelson interferometer. See the section: *The next generation Lightgate S and Lightgate P systems with LightSpeed technology.*

### Photopolymer dot-matrix holograms

In 2008, Bayer AG tasked me with creating what is believed to be the world's first photopolymer dot-matrix digital reflection holograms using their Bayfol® HX photopolymer film. I did so by contact copying directly from a metalized reflective surface-relief dot-matrix master hologram, namely a nickel-metal hologram. I also promoted this technique as a potential mass-reproduction process for photopolymer hologram copies. These photopolymer reflection holograms were shown at the 2008 HoloPack-HoloPrint conference in Toronto, Canada, and, under an NDA, to Du Pont Holographics in Utah, USA, the following week.

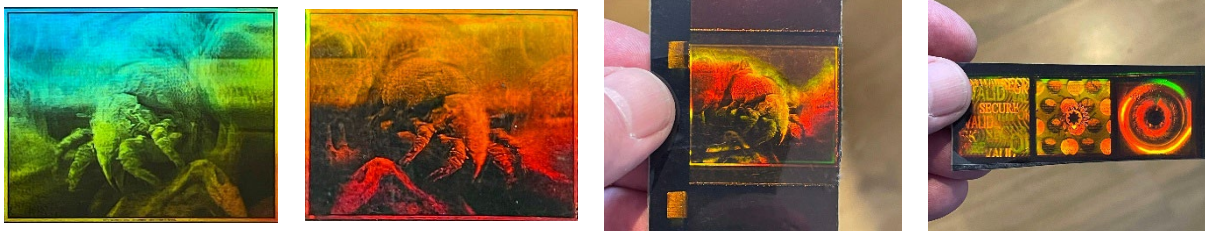

Left: *Vegetable Mite* – A 3Digital nickel-metal surface-relief dot-matrix hologram created using electron microscope images.  
Centre (two): A Bayfol HX photopolymer reflection dot-matrix hologram contact copied from the hologram to the left.  
Right: Bayfol HX photopolymer reflection dot-matrix security holograms.

## Awards

Spatial Imaging's inventions have won five technology related ***International Hologram Manufacturers Awards of Excellence***:

### **2000 Category: New Holographic Technique**

**3Digital** – was the method I devised for creating three-dimensional, wide-angle, digital 'dot-matrix' holographic stereograms using the Lightgate dot-matrix hologram mastering system.

### **2005 Category: New Holographic Technique and BEST OF THE YEAR**

**The Lightgate P2 with Lightspeed technology** – was the world's first commercially available, largest format and fastest digital hologram design and mastering system enabling the creation of large-format, single-image, seamless digital 'dot-matrix' holograms and diffractive patterns.

### **2006 Category: New Holographic Technique**

**The Hydra image capture system** – was a unique multiple-camera system for the capture of parallax image sequences. The Hydra system was able to instantaneously capture a sequence of images, automatically register those images for smooth 3D / animation and generate any number of intermediate frames using 'parallax rendering'. The image sequence was then be used to make three-dimensional dot-matrix holographic stereograms or lenticular images, particularly portraits. The system was technically conceived and designed by my co-director and business partner, Jeffrey Robb, for a subsidiary company named FaceStation Ltd.

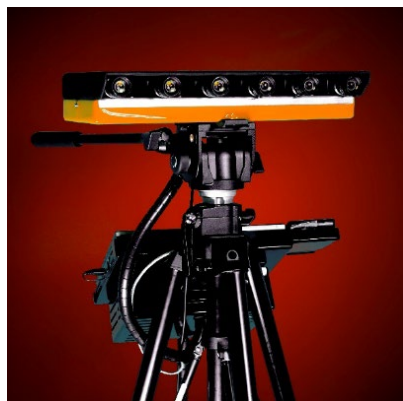

*The Hydra image capture system*

### **2008 Category: Industrial**

**Fast Track** – was an optional component of Spatial Imaging's ultra-high-speed digital hologram mastering platform, enabling the extremely rapid recording of digital holograms. It allowed the recording medium to move continuously while maintaining precise 'plate tracking', so that diffractive pixels could be written accurately onto the moving substrate.

## Credits

My sincere thanks go to the following individuals, each of whom played a vital role in the success of Spatial Imaging's technology business.

**Jeffrey Robb** worked alongside me for fifteen years, from the sale of my first mastering system in 1994 through to 2009. During this time, he supported the DI-HO and Lightgate technology business by installing systems, designing and producing promotional and security holograms, writing educational materials, technical manuals, conference papers and magazine articles, and representing the company at technical conferences.

**Olivier Pitavy** served as my primary technical right-hand man from 2002 to 2009 and continued to support the business thereafter as an external consultant. He built, tested, installed, and supported Spatial Imaging's range of Lightgate mastering systems, travelling the world with me. When the chips were down, a system component had failed, or the owner of a hologram company in the depths of China misunderstood the capabilities of the system, it was Olivier's patience, confidence, and quiet stoicism that always saved the day.

**Dr Paul Apte** of Rideo Systems Ltd. in the UK, has been an integral part of the success of my technology initiatives for more than twenty years, and continues to work on Lightgate projects. Paul has devised numerous motion-control solutions, contributed major software enhancements, and in recent years has designed, built, and installed new generations of Lightgate systems for leading hologram companies around the world.

**Neil Anderson** of C&L Developments Ltd. in the UK has, from the late 1990s to the present day, skilfully designed and crafted, with the utmost of patience, every custom component required for my plethora of hologram mastering systems and related technologies. Neil's other claim to fame is that he designed and built the legs for the Star Wars robot R2-D2!

## Conclusion

Between 1996 and 2008, the technology business of Spatial Imaging, from designing new systems to writing the software to control them, and from building the machines to installing and supporting them around the world, was sustained and driven by myself with the exceptionally small core team listed above. Since 2008, the operation has been carried forward by me alone, working in continued collaboration with Paul Apte and Neil Anderson.

Despite this exceptionally small operational base, Spatial Imaging has, over the past three decades, delivered more than one hundred digital hologram mastering systems and associated technologies, to companies both large and small throughout the world. Working within what remains a very small and highly specialised global industry, the company has maintained a uniquely long, consistent, and productive presence. Its portfolio of world-leading and best-selling systems includes its DI-HO system, its Lightgate range, and, in more recent years, the paradigm shifting direct-write lithography systems developed by 4Pico B.V., and now produced by Raith Laser Systems B.V., in The Netherlands, for which it is the worldwide exclusive distributor.

Taken together, this represents the largest number of professional digital hologram mastering systems supplied by any company in the world to date, a testament to both the longevity of Spatial Imaging and the technical distinctiveness of its inventions and solutions.

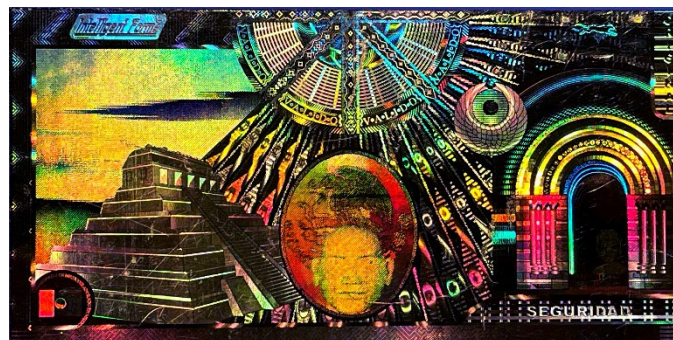

*A sample Lightgate dot-matrix hologram made by Spatial Imaging's customer, Formas Inteligentes, Monterrey, Mexico.*



Once the H1 master hologram has been produced it is possible to make an H2 hologram transfer or secondary master hologram using photoresist. This is the hologram that is subsequently copied using electroforming methods and embossed. An H2 transfer is made by building an entirely different optical camera. Unless the holographer has access to two holographic studios it is usually necessary to completely dismantle the mastering camera to build the transfer camera. In essence the holographic image recorded by the H1 master hologram is transferred holographically to the H2 transfer plate i.e. a hologram is made of a hologram. This is achieved by using the H1 master hologram as an object. The H1 is first illuminated using a collimated coherent laser beam in such a way as to produce a projected or 'real' image of the original object. The H2 transfer plate is then placed such that it cuts the real image produced by the master hologram through the middle. This position is called the 'image plane'. Again, a reference beam of coherent laser light is made to illuminate the H2 transfer plate and, as before, it must have come from the same laser as the object beam, be approximately equal in length, depending on the coherence length of the laser, be the same polarisation and both beams must expose the plate from the same side. To make a rainbow type hologram the master hologram must be illuminated in a special way. Rather than illuminating the entire master hologram with laser light it must be illuminated with a horizontal line or 'slit' of light. Again, once the entire optical set up or 'camera' has been built and tested, a procedure that can take another day to complete, an exposure is made. The H2 transfer hologram is then developed. A typical traditional transferring camera is shown below:

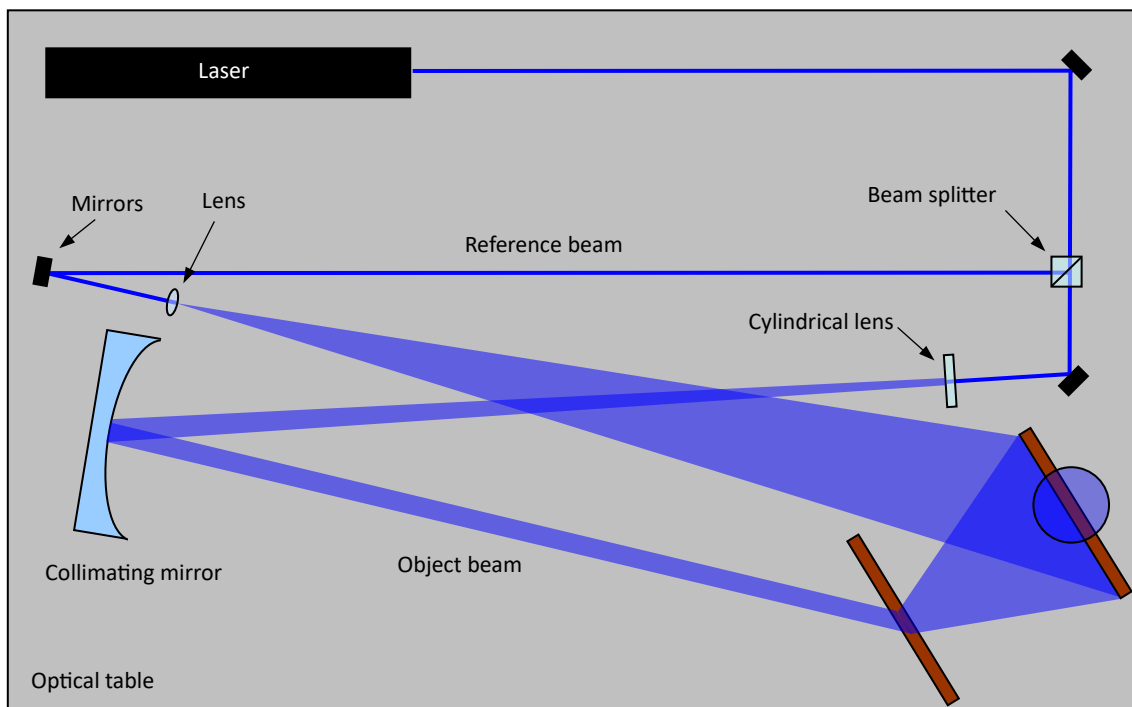

*A typical traditional H2 hologram transfer camera*

## Diffraction gratings

A traditional 3D hologram that has been made of a diffuse object is effectively a recording of millions of points of light in space, each point of light making up the 3D object. A diffraction grating can be thought of as a 3D hologram which has recorded only a single point of light i.e. the 'object' recorded is the simplest possible. A diffraction grating therefore is the most basic kind of hologram.

To make a traditional diffraction grating all one must do is to illuminate an unexposed plate with two coherent beams of laser light. The object beam is not reflected from an object but is instead spread using a lens and shone directly onto the plate. The 'object' is simply the point source of light that is created by a lens.

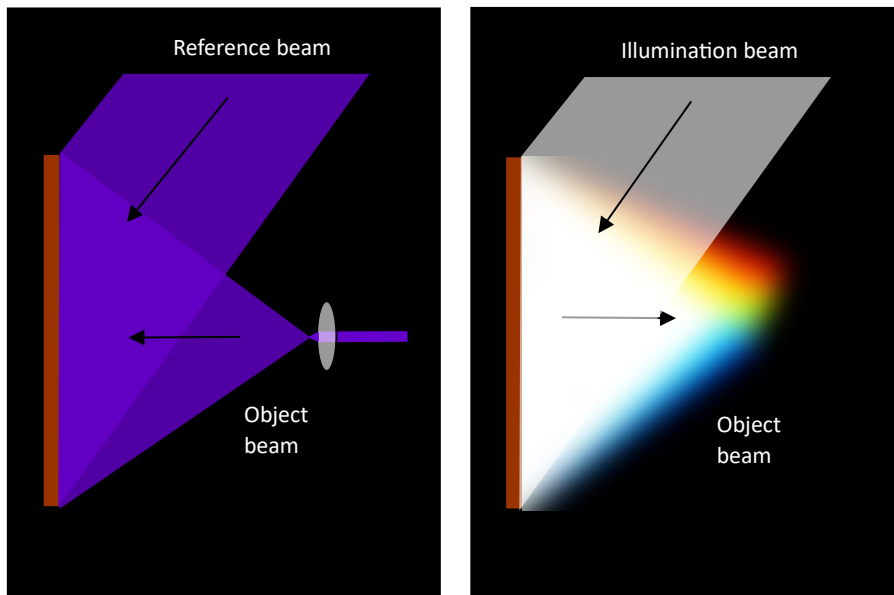

*Left: Making a traditional diffraction grating, Right: Replaying the diffraction grating with white light*

Once the diffraction grating has been processed it is possible to replay the image in the usual way. If the diffraction grating is illuminated with white light however it acts like a prism and diffracts the white light into its constituent colours. Each colour of the spectrum forms its own image of the original object, in this case a single point of light, but does so in a slightly different vertical position. The point of light therefore appears smeared and spectral in nature. This is why diffraction gratings change in colour through the spectrum as they are tilted.

### **Dot-matrix holography**

Traditional holography records an entire hologram with a single exposure. Dot-matrix holography, on the other hand, creates a hologram from thousands, sometimes millions of individual sub-holograms or holographic pixels using two focussed beams of laser light that converge to a single point to create a simple plane-wave diffraction grating. When illuminated, these diffractive pixels redirect light to predetermined viewing locations in space. The light diffracted from many tens of thousands of such pixels combines to form a complete holographic image.

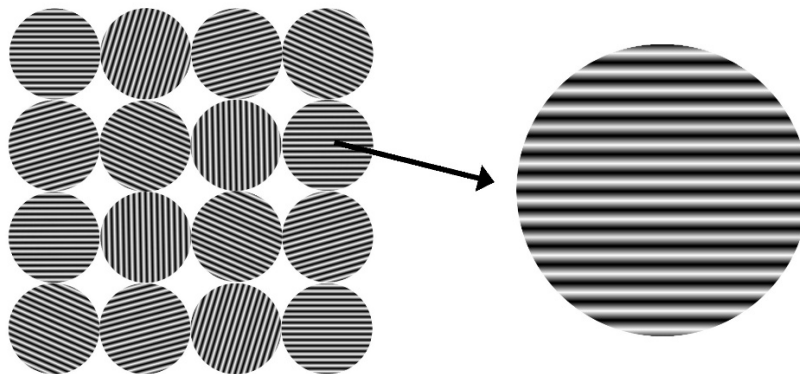

Each diffractive pixel in the hologram diffracts light at a specific angle and in a direction that was determined when the hologram was made. The angle and direction that a pixel's grating diffracts light is specified by two factors - the grating orientation and the grating spatial frequency.

**1. The grating orientation.** The diffraction grating can be recorded in any orientation from 0 to 180 degrees. This is achieved by rotating the two laser beams.

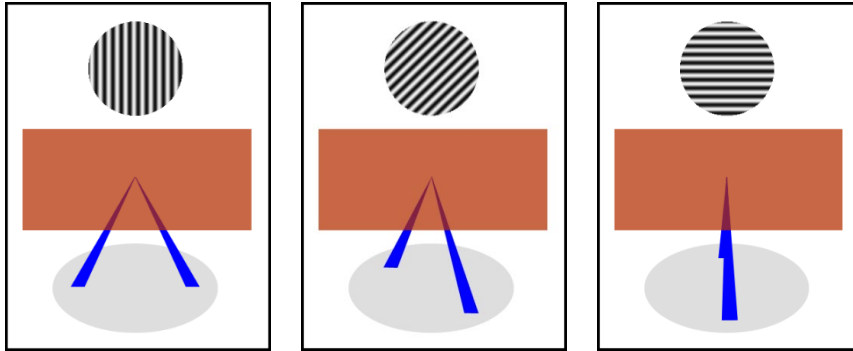

**2. The grating spatial frequency.** Different grating spatial frequencies, i.e. the number of interference fringes per mm, can also be recorded. This is achieved by changing the angle between the two laser beams.

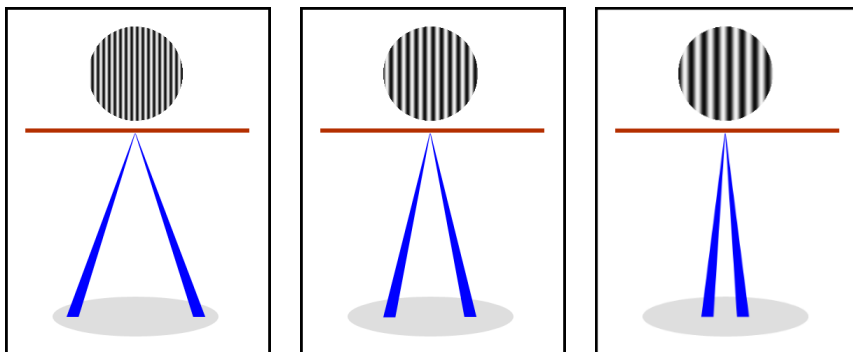

These two factors, the grating orientation and the grating spatial frequency, determine precisely the angle and direction that the light will diffract from each pixel.

### Changing the grating orientation

By changing the grating orientation, the diffracted light can be made to skew horizontally left or right with respect to the vertical axis. Pixels with different grating orientations will therefore 'light up' from different angles and create the animated effect seen in 'kinetic' type digital holograms.

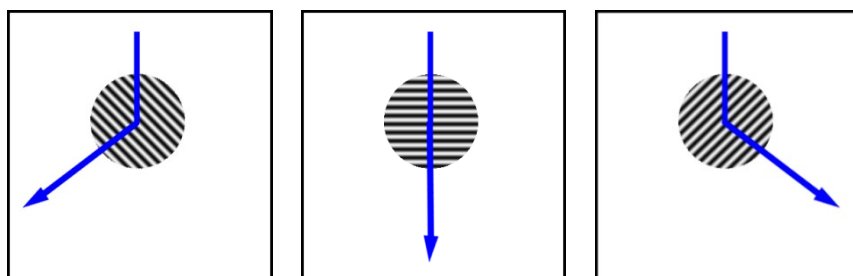

### Changing the grating spatial frequency

By changing the grating spatial frequency, the diffracted light can be made to skew vertically up or down with respect to the horizontal axis. As with all 'rainbow' holograms the angle that the light diffracts in the vertical direction determines the apparent colour of the hologram i.e. the portion of the spectrum that the viewer sees when viewing the hologram from a particular position. The vertical diffraction angle is primarily determined by the grating spacing of the hologram or, in the case of Lightgate digital holograms, the grating spacing of each diffractive pixel. The Lightgate system's ability to vary the grating spacing of each pixel enables the production of multi-colour and full colour digital holograms. By selecting particular a grating spacing each pixel can be assigned a different colour of the spectrum. It is important to remember however that, like all 'rainbow' holograms, the colours are relative not actual. For example, when one pixel appears red another can appear blue. When the hologram is tilted or the illumination beam angle changes however the colour of the pixels will change and shift through the colours of the spectrum.

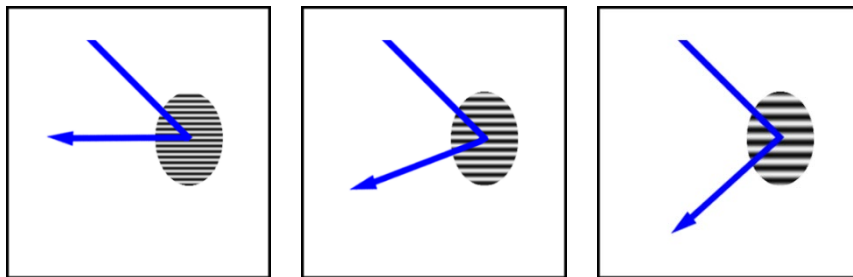

### How the grating characteristics are specified

The Lightgate system's optical technology automatically adjusts the two focussed laser beams so as to produce the desired grating orientation and spacing for each pixel. It does this 'on the fly', pixel by pixel, as the hologram is being recorded. The Lightgate Control software therefore needs to know the desired grating orientation and spacing for each pixel in the hologram. The Lightgate system utilises two different techniques to determine these values. These techniques can be used separately or combined to produce sophisticated holograms.

1. The use of one or several computer bitmap images.
  - a. A single grey scale image
  - b. Two or more grey scale images
  - c. A single multi-colour image
  - d. A single full colour image
2. The use of pre-installed custom computer software algorithms.

#### 1. The use of one or several bit-mapped computer images.

##### a) A single grey scale image used to make a single colour hologram

A single grey scale computer image can be used to specify the grating orientation and spacing values for a single colour hologram. Each pixel in the computer image is used to define a corresponding diffractive pixel in the hologram. Traditional 'kinetic' digital holograms are made by simply rotating two laser beams to change the grating orientation for each pixel. Such holograms are usually 'single colour' and it is therefore not necessary to vary the grating spacing for any of the pixels. To make such a hologram, the grating orientation for each pixel is determined by the grey level, from 0 to 255, of the corresponding pixel in the computer image. Pixels in the computer image that are grey level 128 (50% grey) create diffractive pixels that diffract the light vertically.

White pixels create diffractive pixels that skew the diffracted light to the left and black pixels skew the diffracted light to the right.

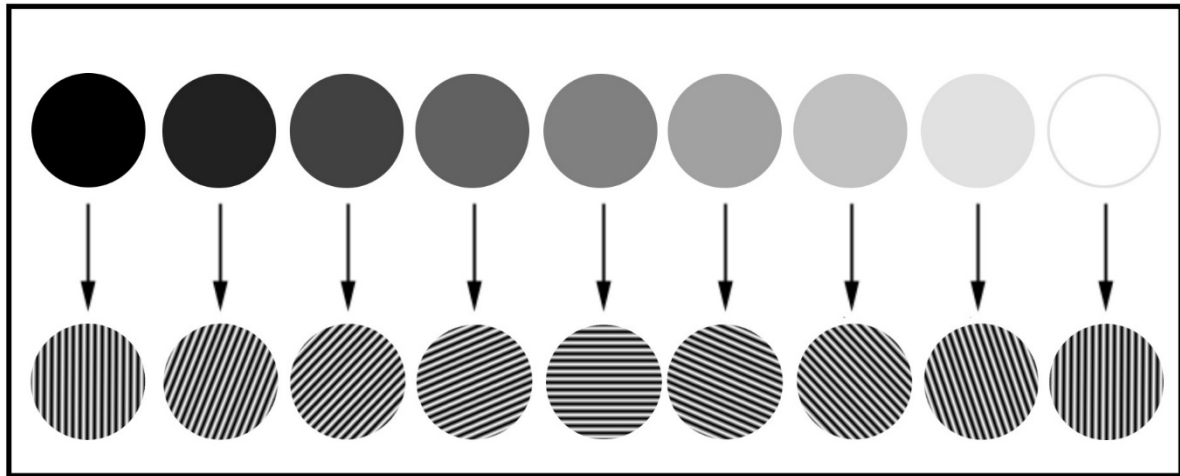

Whichever type of computer image is loaded into the Lightgate Control program, it is first converted into a 24-bit RGB image comprising three colour channels - red, green, and blue. The greyscale value used to determine the grating orientation is taken from one of these channels (the blue channel is used by default). Shown below is a typical greyscale computer image alongside a representation of the single-colour kinetic dot-matrix hologram that can be generated from it.”

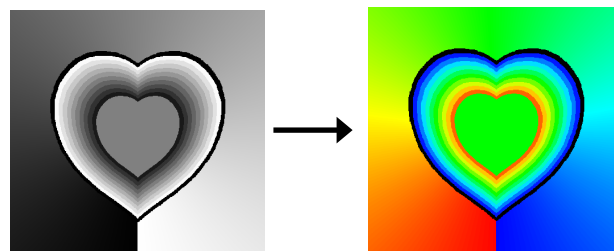

**b) Two or more grey scale images are used to make a multi-colour hologram**

Grating spatial frequency can be specified by using more than one greyscale computer image. A multiple colour hologram, with many discrete spectral colours, can be made by using several computer images, one for each colour in the final hologram. Care is taken not to overlap areas of differently colour pixels by masking the images from each other using the colour black - grey level 0. The Lightgate printer does not expose pixels that have a grey level of 0. Shown below are two grey scale computer images that, if printed in register, would make the two-colour kinetic type dot-matrix hologram depicted on the right.

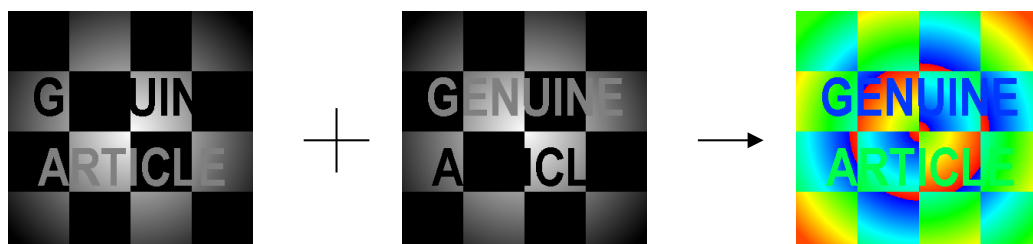

**c) A single multi-colour image used to make a multi-colour hologram**

A multiple or multi-colour image, as opposed to a full colour image, contains a number of discrete block colours. With this technique, rather than use a greyscale image i.e. an image which graduates from black to white, it is possible to use a coloured image i.e. an image which graduates from black to blue or from black to red etc. In this case the colour of an image, or an area of an image, determines the colour or spatial frequency of the hologram whilst the tonal variation, as before, determines the grating orientation. This technique allows the mastering of multi-colour kinetic type holograms using only one bitmap image.

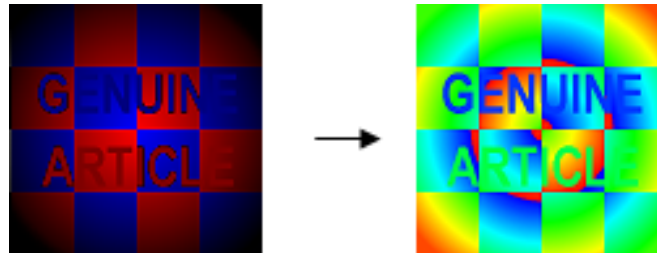

**d) A single full colour image used to make a full colour hologram**

A further technique is to specify both the grating orientation and the grating spacing at the same time using a full colour computer image. In this case an RGB, full colour, dot-matrix hologram is created. This is achieved by either triple exposing each pixel or by spatially separating the red, green and blue pixels in the hologram.

The Lightgate printer currently offers four RGB, full colour, recording methods.

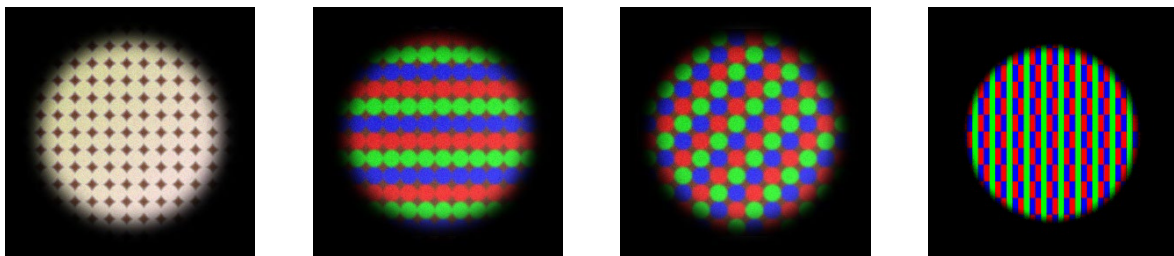

*Triple exposed*

*Linear spliced*

*Chequerboard spliced*

*Sub Pixel spliced*

**Triple exposed RGB**, creates a full colour hologram by exposing each pixel three times. The angle between the two laser beams and hence the grating spacing is changed for each of the three exposures to produce a single pixel that diffracts red, green and blue light.

**Linear spliced RGB** creates a full colour hologram by recording the red, green and blue pixels of an image in horizontal stripes.

**Chequerboard spliced RGB** creates a full colour hologram by recording the red, green and blue pixels of an image in a chequerboard pattern (recommended).

**Sub-pixel spliced RGB** creates a full colour hologram by recording red, green and blue sub-pixels for each pixel in the image.

The three latter RGB features enable the Lightgate user to produce full colour holograms in the same time that it would normally take to record a single colour hologram. Also, as each pixel contains only one diffraction grating, the brightness and saturation of the pixel is not compromised.

For all four options, the grating orientation is determined as usual by the grey level value of each pixel in the computer image however, in this case, the colour channel from which the grey level value is taken depends upon which colour is being recorded. For example, if a red exposure is being made the grey level value of the pixel's red channel is used to determine the pixel's grating orientation. This technique produces a full colour 'kinetic' type digital hologram using only a single computer image. Full colour, multi-channel or three-dimensional holograms can also be made by combining these RGB, full colour recording techniques with the algorithmic techniques described below.

## **2. The use of pre-installed custom computer software algorithms.**

The techniques described above utilise one or more computer images to determine the grating orientation and the grating spacing for each pixel in a Lightgate digital hologram. The Lightgate printer however can also make extremely sophisticated digital holograms by utilising pre-installed software algorithms to determine the grating orientation and grating spacing. In other words, the Lightgate system's control program itself can determine the grating orientation and/or grating spacing for each pixel in the dot-matrix hologram using mathematical formulae.

The simplest example of this is a technique is commonly called a 'sparkle' or 'random angle' effect. This technique creates the glitter-like effect often seen in kinetic dot-matrix holograms. In this instance the grating orientation for each pixel is determined randomly by the computer software and not by the computer image. Another example is the 3D dot-matrix holographic stereogram technique – called 3Digital. In this case the software accurately calculates the grating orientation and grating spatial frequency for each pixel so that the diffracted light from every pixel in the hologram converges to form discrete stereographic viewing zones some distance in front of the hologram. As mentioned above, this technique can be combined with the RGB, full colour, techniques described above to make full colour or achromatic three-dimensional holograms. For algorithmic techniques, the grey level of each pixel is used to determine the intensity or brightness of the corresponding diffractive pixel. This is achieved by modulating the exposure time given to each diffractive pixel. In this way 'photographic' or 'shaded image' dot-matrix holograms can be produced.

Other types of algorithmically produced digital holograms or holographic effects include laser projected covert hidden images, algorithmic gradient patterns, curved holograms, multi-channel effects and digital holographic optical elements. The Lightgate dot-matrix hologram shown below contains many optical features and effects.

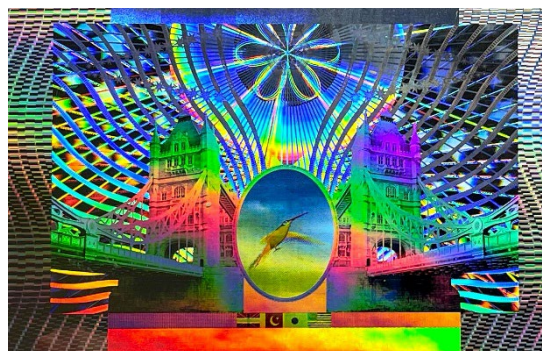

*A sample Lightgate dot-matrix hologram made by Rob Munday, Jeffrey Robb, and Olivier Pitavy of Spatial Imaging.*



*Spatial Imaging's first Lightgate P1, large format dot-matrix hologram, 2002. Its purpose was to demonstrate the potential of overprinting images onto dot-matrix holograms in register, using translucent inks to create a dynamic and visually striking magazine cover (the hologram above has not yet been overprinted).*



